



FCC TEST REPORT (PART 15)

REPORT NO.: RF950915L21

MODEL NO.: TITA100

RECEIVED: Sep. 18, 2006

TESTED: Sep. 21 ~ Sep. 25, 2006

ISSUED: Oct. 02, 2006

APPLICANT: High Tech Computer Corp.

ADDRESS: 23, Hsin-Hua Rd., Taoyuan, 330, Taiwan, R.O.C.

ISSUED BY: Advance Data Technology Corporation

LAB ADDRESS: No. 47, 14th Ling, Chia Pau Tsuen, Lin Kou Hsiang 244, Taipei Hsien, Taiwan, R.O.C.

TEST LOCATION: No. 19, Hwa Ya 2nd Rd., Wen Hwa Tsuen, Kwei Shan Hsiang, Taoyuan Hsien 333, Taiwan, R.O.C.

This test report consists of 99 pages in total. It may be duplicated completely for legal use with the approval of the applicant. It should not be reproduced except in full, without the written approval of our laboratory. The client should not use it to claim product endorsement by CNLA, A2LA or any government agencies. The test results in the report only apply to the tested sample.





TABLE OF CONTENTS

| | | |
|-------|---|----|
| 1. | CERTIFICATION | 4 |
| 2. | SUMMARY OF TEST RESULTS | 5 |
| 2.1 | MEASUREMENT UNCERTAINTY..... | 5 |
| 3. | GENERAL INFORMATION | 6 |
| 3.1 | GENERAL DESCRIPTION OF EUT | 6 |
| 3.2 | DESCRIPTION OF TEST MODES | 8 |
| 3.2.1 | CONFIGURATION OF SYSTEM UNDER TEST | 9 |
| 3.2.2 | TEST MODE APPLICABILITY AND TESTED CHANNEL DETAIL:..... | 10 |
| 3.3.3 | GENERAL DESCRIPTION OF APPLIED STANDARDS | 13 |
| 3.3.4 | DESCRIPTION OF SUPPORT UNITS..... | 13 |
| 4. | TEST TYPES AND RESULTS..... | 14 |
| 4.1 | CONDUCTED EMISSION MEASUREMENT | 14 |
| 4.1.1 | LIMITS OF CONDUCTED EMISSION MEASUREMENT | 14 |
| 4.1.2 | TEST INSTRUMENTS..... | 14 |
| 4.1.3 | TEST PROCEDURES | 15 |
| 4.1.4 | DEVIATION FROM TEST STANDARD | 15 |
| 4.1.5 | TEST SETUP | 16 |
| 4.1.6 | EUT OPERATING CONDITIONS | 16 |
| 4.1.7 | TEST RESULTS..... | 17 |
| 4.2 | RADIATED EMISSION MEASUREMENT | 59 |
| 4.2.1 | LIMITS OF RADIATED EMISSION MEASUREMENT | 59 |
| 4.2.2 | TEST INSTRUMENTS..... | 60 |
| 4.2.3 | TEST PROCEDURES | 61 |
| 4.2.4 | DEVIATION FROM TEST STANDARD | 61 |
| 4.2.5 | TEST SETUP | 62 |
| 4.2.6 | EUT OPERATING CONDITIONS | 62 |
| 4.2.7 | TEST RESULTS..... | 63 |
| 4.3 | NUMBER OF HOPPING FREQUENCY USED | 73 |
| 4.3.1 | LIMIT OF HOPPING FREQUENCY USED | 73 |
| 4.3.2 | TEST INSTRUMENTS..... | 73 |
| 4.3.3 | TEST PROCEDURES | 73 |
| 4.3.4 | DEVIATION FROM TEST STANDARD | 74 |
| 4.3.5 | TEST SETUP | 74 |
| 4.3.6 | TEST RESULTS..... | 74 |
| 4.4 | DWELL TIME ON EACH CHANNEL | 76 |
| 4.4.1 | LIMIT OF DWELL TIME USED..... | 76 |
| 4.4.2 | TEST INSTRUMENTS..... | 76 |
| 4.4.3 | TEST PROCEDURES | 76 |
| 4.4.4 | DEVIATION FROM TEST STANDARD..... | 76 |
| 4.4.5 | TEST SETUP | 77 |
| 4.4.6 | TEST RESULTS..... | 77 |
| 4.5 | CHANNEL BANDWIDTH..... | 81 |
| 4.5.1 | LIMITS OF CHANNEL BANDWIDTH..... | 81 |
| 4.5.2 | TEST INSTRUMENTS..... | 81 |
| 4.5.3 | TEST PROCEDURE..... | 81 |
| 4.5.4 | DEVIATION FROM TEST STANDARD | 82 |
| 4.5.5 | TEST SETUP | 82 |
| 4.5.6 | EUT OPERATING CONDITION | 82 |
| 4.5.7 | TEST RESULTS..... | 82 |



| | |
|---|-----|
| 4.6 HOPPING CHANNEL SEPARATION | 85 |
| 4.6.1 LIMIT OF HOPPING CHANNEL SEPARATION..... | 85 |
| 4.6.2 TEST INSTRUMENTS..... | 85 |
| 4.6.3 TEST PROCEDURES | 85 |
| 4.6.4 DEVIATION FROM TEST STANDARD..... | 86 |
| 4.6.5 TEST SETUP | 86 |
| 4.6.6 TEST RESULTS..... | 86 |
| 4.7 MAXIMUM PEAK OUTPUT POWER..... | 89 |
| 4.7.1 LIMITS OF MAXIMUM PEAK OUTPUT POWER MEASUREMENT | 89 |
| 4.7.2 TEST INSTRUMENTS..... | 89 |
| 4.7.3 TEST PROCEDURES | 89 |
| 4.7.4 DEVIATION FROM TEST STANDARD..... | 89 |
| 4.7.5 TEST SETUP | 90 |
| 4.7.6 EUT OPERATING CONDITION | 90 |
| 4.7.7 TEST RESULTS..... | 90 |
| 4.8 BAND EDGES MEASUREMENT | 93 |
| 4.8.1 LIMITS OF BAND EDGES MEASUREMENT | 93 |
| 4.8.2 TEST INSTRUMENTS..... | 93 |
| 4.8.3 TEST PROCEDURE..... | 93 |
| 4.8.4 DEVIATION FROM TEST STANDARD..... | 93 |
| 4.8.5 EUT OPERATING CONDITION | 93 |
| 4.8.6 TEST RESULTS..... | 94 |
| 4.9 ANTENNA REQUIREMENT | 97 |
| 4.9.1 STANDARD APPLICABLE | 97 |
| 4.9.2 ANTENNA CONNECTED CONSTRUCTION..... | 97 |
| 5. INFORMATION ON THE TESTING LABORATORIES..... | 98 |
| APPENDIX-A..... | A-1 |



1. CERTIFICATION

PRODUCT: Pocket PC Phone
MODEL NO.: TITA100
TEST SAMPLE: ENGINEERING SAMPLE
TESTED: Sep. 21 ~ Sep. 25, 2006
APPLICANT: High Tech Computer Corp.
STANDARDS: FCC Part 15, Subpart C (Section 15.247),
ANSI C63.4-2003

The above equipment have been tested by **Advance Data Technology Corporation**, and found compliance with the requirement of the above standards. The test record, data evaluation & Equipment Under Test (EUT) configurations represented herein are true and accurate accounts of the measurements of the sample's EMC characteristics under the conditions specified in this report.

PREPARED BY : Andrea Hsia , **DATE:** Oct. 02, 2006
Andrea Hsia

TECHNICAL ACCEPTANCE : Long Chen , **DATE:** Oct. 02, 2006
Responsible for RF Long Chen

APPROVED BY : Gary Chang , **DATE:** Oct. 02, 2006
Gary Chang / Supervisor

2. SUMMARY OF TEST RESULTS

The EUT has been tested according to the following specifications:

| APPLIED STANDARD: FCC Part 15, Subpart C | | | |
|--|---|--------|--|
| STANDARD SECTION | TEST TYPE AND LIMIT | RESULT | REMARK |
| 15.207 | AC Power Conducted Emission | PASS | Meet the requirement of limit Minimum passing margin is -4.54dB at 0.400MHz. |
| 15.247(a)(1)(iii) | Number of Hopping Frequency Used Spec.: At least 15 channels | PASS | Meet the requirement of limit |
| 15.247(a)(1)(iii) | Dwell Time on Each Channel Spec. : Max. 0.4 second within 31.6 second | PASS | Meet the requirement of limit |
| 15.247(a)(1) | 1. Hopping Channel Separation Spec. : Min. 25 kHz or 20 dB bandwidth, whichever is greater 2. Spectrum Bandwidth of a Frequency Hopping Sequence Spread Spectrum System | PASS | Meet the requirement of limit |
| 15.247(b) | Maximum Peak Output Power Spec.: max. 30dBm | PASS | Meet the requirement of limit |
| 15.247(d) | Transmitter Radiated Emissions Spec.: Table 15.209 | PASS | Meet the requirement of limit Minimum passing margin is -3.41 dB at 51.38MHz. |
| 15.247(d) | Band Edge Measurement | PASS | Meet the requirement of limit |

2.1 MEASUREMENT UNCERTAINTY

Where relevant, the following measurement uncertainty levels have been estimated for tests performed on the EUT as specified in CISPR 16-4:

| MEASUREMENT | FREQUENCY | UNCERTAINTY |
|---------------------|-----------------|-------------|
| Conducted emissions | 9kHz ~ 30MHz | 2.44 dB |
| Radiated emissions | 30MHz ~ 200MHz | 3.59 dB |
| | 200MHz ~1000MHz | 3.61 dB |
| | 1GHz ~ 18GHz | 2.26 dB |
| | 18GHz ~ 40GHz | 1.94 dB |

This uncertainty represents an expanded uncertainty expressed at approximately the 95% confidence level using a coverage factor of k=2.



3. GENERAL INFORMATION

3.1 GENERAL DESCRIPTION OF EUT

| | |
|------------------------------|--|
| PRODUCT | Pocket PC Phone |
| MODEL NO. | TITA100 |
| FCC ID | NM8TITA100 |
| POWER SUPPLY | 3.70Vdc from rechargeable lithium battery 5.00Vdc from power adapter or cradle 5.00Vdc from host equipment |
| MODULATION TYPE | GFSK for FHSS |
| MODULATION TECHNOLOGY | FHSS |
| TRANSFER RATE | 723Kbps |
| FREQUENCY RANGE | 2.402 ~ 2.480GHz |
| NUMBER OF CHANNEL | 79 |
| OUTPUT POWER | 1.064mW |
| ANTENNA TYPE | PIFA antenna with 0dBi gain |
| DATA CABLE | 1.5m USB non-shielded cable without core 1.6m non-shielded cable for Earphone |
| I/O PORTS | Refer to user's manual |
| ASSOCIATED DEVICES | Belt chip, Pouch, Cradle, Earphone |

NOTE:

1. The applicant defined the normal working voltage of the battery is from 3.6Vdc to 4.2Vdc.
2. The EUT have two different appearances.
3. The EUT is a CDMA850/CDMA1900 Pocket PC Phone with wireless LAN and bluetooth functions. This report is only covered the functions of bluetooth. The wireless LAN is covered in the other test report, which standards used also FCC Part 15. The mobile phone function is covered in another two test reports, which standards used are FCC Part 24 and FCC Part 22.
4. The EUT have lithium batteries listed as below:

| | |
|-------------------|---|
| BATTERY 1: | |
| BRAND: | Dynapack International Technology Corporation |
| MODEL: | TRIN160 |
| RATING: | 3.7Vdc, 1500mAh |

| | |
|-------------------|---------------------------|
| BATTERY 2: | |
| BRAND: | SK mobile energy CO., LTD |
| MODEL: | TRIN160 |
| RATING: | 3.7Vdc, 1500mAh |

NOTE: After pre-tested both batteries and both model, found TITA100 with batter 1 is worse, therefore all the test results came out from this.

5. The EUT was operated with following power adapters:

| ADAPTER 1: | |
|--------------------|---|
| BRAND: | DELTA ELECTRONIC, INC. |
| MODEL: | ADP-5FH B |
| INPUT: | 100-240Vac ~ 50-60Hz, 0.2A, |
| OUTPUT: | 5.0Vdc, 1A |
| POWER LINE: | DC 1.8m non-shielded cable without core |

| ADAPTER 2: | |
|--------------------|---|
| BRAND: | PHIHONG |
| MODEL: | PSAA05A-050 |
| INPUT: | 100~240Vac, 200mA, 50-60Hz |
| OUTPUT: | 5.0Vdc, 1A |
| POWER LINE: | DC 1.8m non-shielded cable without core |

6. The EUT was operated with following charging cradle:

| | |
|----------------|------------|
| MODEL: | TITA150 |
| OUTPUT: | 5.0Vdc, 1A |

7. The EUT operates in the 2.4GHz frequency spectrum and complies with 802.11b & 802.11g techniques.

8. The above EUT information was declared by manufacturer and for more detailed features description, please refer to the manufacturer's specifications or User's Manual.

9. The EUT used the same antenna in Wireless LAN & Bluetooth function, but the two functions can not work at the same time.

3.2 DESCRIPTION OF TEST MODES

Since the EUT is considered a portable unit, it was pre-tested on the positioned of each 3 axis. For wireless LAN function, the worst case was found when positioned on Z-plane. Therefore only the test data of this Z-plane was used for radiated test.

There are 7 test modes presented in the report as below.

| TEST MODE | TEST CONDITION |
|-----------|---|
| A | The EUT with battery 1, and was powered by the adapter 1. |
| B | The EUT with battery 1, and was powered by the adapter 2. |
| C | The EUT with battery 1 connected with the earphone via USB cable, and was powered by the adapter 1 via USB cable. |
| D | The EUT with battery 1 connected with the earphone via USB cable, and was powered by the adapter 2 via USB cable. |
| E | The EUT with battery 1 connected with the earphone and notebook via USB cable, and was powered by notebook. |
| F | The EUT with battery 1 connected with the cradle, and was powered by the adapter 1. |
| G | The EUT with battery 1 connected with the cradle, and was powered by the adapter 2. |

79 channels are provided to this EUT for bluetooth function:

| CHANNEL | FREQ. (MHz) | CHANNEL | FREQ. (MHz) | CHANNEL | FREQ. (MHz) | CHANNEL | FREQ. (MHz) |
|---------|-------------|---------|-------------|---------|-------------|---------|-------------|
| 0 | 2402 | 20 | 2422 | 40 | 2442 | 60 | 2462 |
| 1 | 2403 | 21 | 2423 | 41 | 2443 | 61 | 2463 |
| 2 | 2404 | 22 | 2424 | 42 | 2444 | 62 | 2464 |
| 3 | 2405 | 23 | 2425 | 43 | 2445 | 63 | 2465 |
| 4 | 2406 | 24 | 2426 | 44 | 2446 | 64 | 2466 |
| 5 | 2407 | 25 | 2427 | 45 | 2447 | 65 | 2467 |
| 6 | 2408 | 26 | 2428 | 46 | 2448 | 66 | 2468 |
| 7 | 2409 | 27 | 2429 | 47 | 2449 | 67 | 2469 |
| 8 | 2410 | 28 | 2430 | 48 | 2450 | 68 | 2470 |
| 9 | 2411 | 29 | 2431 | 49 | 2451 | 69 | 2471 |
| 10 | 2412 | 30 | 2431 | 50 | 2452 | 70 | 2472 |
| 11 | 2413 | 31 | 2433 | 51 | 2453 | 71 | 2473 |
| 12 | 2414 | 32 | 2434 | 52 | 2454 | 72 | 2474 |
| 13 | 2415 | 33 | 2435 | 53 | 2455 | 73 | 2475 |
| 14 | 2416 | 34 | 2436 | 54 | 2456 | 74 | 2476 |
| 15 | 2417 | 35 | 2437 | 55 | 2457 | 75 | 2477 |
| 16 | 2418 | 36 | 2438 | 56 | 2458 | 76 | 2478 |
| 17 | 2419 | 37 | 2439 | 57 | 2459 | 77 | 2479 |
| 18 | 2420 | 38 | 2440 | 58 | 2460 | 78 | 2480 |
| 19 | 2421 | 39 | 2441 | 59 | 2461 | | |

3.2.1 CONFIGURATION OF SYSTEM UNDER TEST

TEST MODE A, B,

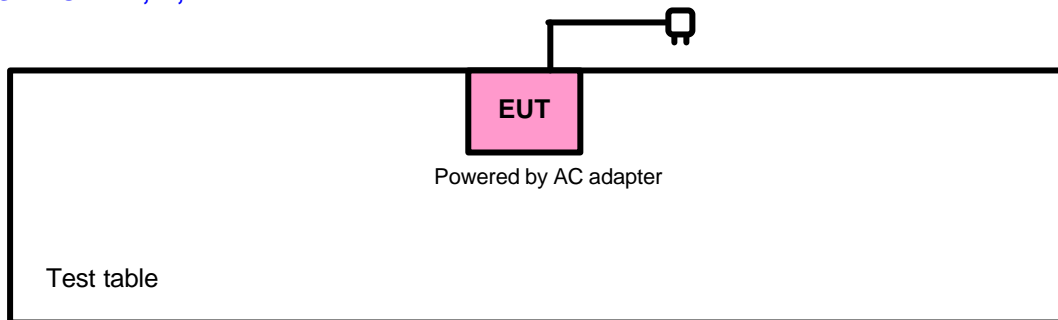

TEST MODE C, D

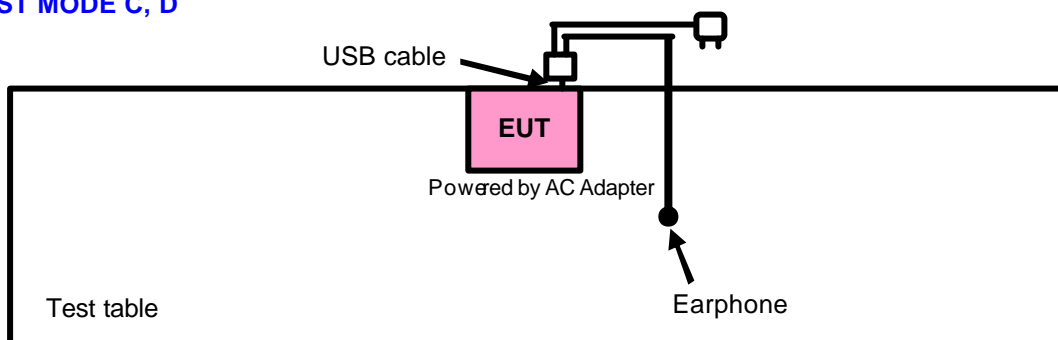

TEST MODE E

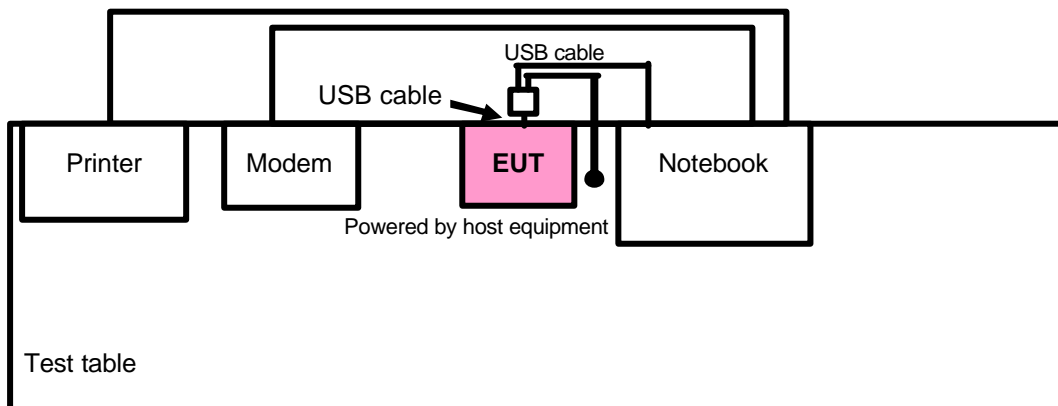

TEST MODE F, G

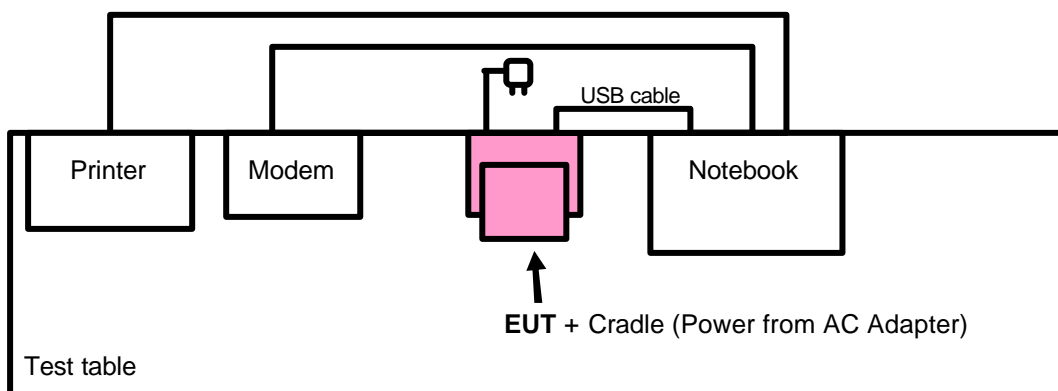

3.2.2 TEST MODE APPLICABILITY AND TESTED CHANNEL DETAIL :

| EUT CONFIGURE MODE | APPLICABLE TO | | | | DESCRIPTION |
|--------------------|---------------|-------|--------------------|------|---|
| | PLC | RE<1G | RE ³ 1G | APCM | |
| A | v | v | - | - | The EUT with battery 1, and was powered by the adapter 1. |
| B | v | v | - | - | The EUT with battery 1, and was powered by the adapter 2. |
| C | v | v | - | - | The EUT with battery 1 connected with the earphone via USB cable, and was powered by the adapter 1 via USB cable. |
| D | v | v | - | - | The EUT with battery 1 connected with the earphone via USB cable, and was powered by the adapter 2 via USB cable. |
| E | v | v | v | v | The EUT with battery 1 connected with the earphone and notebook via USB cable, and was powered by notebook |
| F | v | v | - | - | The EUT with battery 1 connected with the cradle, and was powered by the adapter 1. |
| G | v | v | - | - | The EUT with battery 1 connected with the cradle, and was powered by the adapter 2. |

Where **PLC**: Power Line Conducted Emission
RE³1G: Radiated Emission above 1GHz

RE<1G: Radiated Emission below 1GHz
APCM: Antenna Port Conducted Measurement

NOTE: “-“ means no effect.

POWER LINE CONDUCTED EMISSION TEST:

? Pre-Scan has been conducted to determine the worst-case mode from all possible combinations between available modulations, antenna ports (if EUT with antenna diversity architecture), and packet types.

Following channel(s) was (were) selected for the final test as listed below.

| EUT CONFIGURE MODE | AVAILABLE CHANNEL | TESTED CHANNEL | MODULATION TECHNOLOGY | MODULATION TYPE | PACKET TYPE |
|--------------------|-------------------|----------------|-----------------------|-----------------|-------------|
| A | 0 to 78 | 0, 39, 78 | FHSS | GFSK | DH5 |
| B | 0 to 78 | 0, 39, 78 | FHSS | GFSK | DH5 |
| C | 0 to 78 | 0, 39, 78 | FHSS | GFSK | DH5 |
| D | 0 to 78 | 0, 39, 78 | FHSS | GFSK | DH5 |
| E | 0 to 78 | 0, 39, 78 | FHSS | GFSK | DH5 |
| F | 0 to 78 | 0, 39, 78 | FHSS | GFSK | DH5 |
| G | 0 to 78 | 0, 39, 78 | FHSS | GFSK | DH5 |

RADIATED EMISSION TEST (BELOW 1 GHz):

- ? Pre-Scan has been conducted to determine the worst-case mode from all possible combinations between available modulations, data rates, antenna ports (if EUT with antenna diversity architecture), X, Y, Z Axis, and packet type.
- Following channel(s) was (were) selected for the final test as listed below.

| EUT CONFIGURE MODE | AVAILABLE CHANNEL | TESTED CHANNEL | MODULATION TECHNOLOGY | MODULATION TYPE | PACKET TYPE | AXIS |
|--------------------|-------------------|----------------|-----------------------|-----------------|-------------|------|
| A | 0 to 78 | 78 | FHSS | GFSK | DH5 | Z |
| B | 0 to 78 | 78 | FHSS | GFSK | DH5 | Z |
| C | 0 to 78 | 78 | FHSS | GFSK | DH5 | Z |
| D | 0 to 78 | 78 | FHSS | GFSK | DH5 | Z |
| E | 0 to 78 | 78 | FHSS | GFSK | DH5 | Z |
| F | 0 to 78 | 78 | FHSS | GFSK | DH5 | Z |
| G | 0 to 78 | 78 | FHSS | GFSK | DH5 | Z |

RADIATED EMISSION TEST (ABOVE 1 GHz):

- ? Pre-Scan has been conducted to determine the worst-case mode from all possible combinations between available modulations, data rates, antenna ports (if EUT with antenna diversity architecture), X, Y, Z Axis, and packet type.
- Following channel(s) was (were) selected for the final test as listed below.

| EUT CONFIGURE MODE | AVAILABLE CHANNEL | TESTED CHANNEL | MODULATION TECHNOLOGY | MODULATION TYPE | PACKET TYPE | AXIS |
|--------------------|-------------------|----------------|-----------------------|-----------------|-------------|------|
| E | 0 to 78 | 0, 39, 78 | FHSS | GFSK | DH5 | Z |

BANDEDGE MEASUREMENT:

- ? Pre-Scan has been conducted to determine the worst-case mode from all possible combinations between available modulations, antenna ports (if EUT with antenna diversity architecture), and packet types.
- Following channel(s) was (were) selected for the final test as listed below.

| AVAILABLE CHANNEL | TESTED CHANNEL | MODULATION TECHNOLOGY | MODULATION TYPE | PACKET TYPE |
|-------------------|----------------|-----------------------|-----------------|-------------|
| 0 to 78 | 0, 78 | FHSS | GFSK | DH5 |



ANTENNA PORT CONDUCTED MEASUREMENT:

? Pre-Scan has been conducted to determine the worst-case mode from all possible combinations between available modulations, antenna ports (if EUT with antenna diversity architecture), and packet types.

Following channel(s) was (were) selected for the final test as listed below.

| AVAILABLE CHANNEL | TESTED CHANNEL | MODULATION TECHNOLOGY | MODULATION TYPE | PACKET TYPE |
|-------------------|----------------|-----------------------|-----------------|-------------|
| 0 to 78 | 0, 39, 78 | FHSS | GFSK | DH5 |



3.3.3 GENERAL DESCRIPTION OF APPLIED STANDARDS

The EUT is a RF Product. According to the specifications of the manufacturer, it must comply with the requirements of the following standards:

FCC Part 15, Subpart C. (15.247)

ANSI C63.4- 2003

All test items have been performed and recorded as per the above standards.

NOTE: The EUT is also considered as a kind of computer peripheral, because the connection to computer is necessary for typical use. It has been verified to comply with the requirements of FCC Part 15, Subpart B, Class B (DoC). The test report has been issued separately.

3.3.4 DESCRIPTION OF SUPPORT UNITS

The EUT has been tested as an independent unit together with other necessary accessories or support units. The following support units or accessories were used to form a representative test configuration during the tests.

| NO. | PRODUCT | BRAND | MODEL NO. | SERIAL NO. | FCC ID |
|-----|-------------------|-------|-----------|-------------|------------------|
| 1 | NOTEBOOK COMPUTER | DELL | PP05L | 12130898320 | E2K24CLNS |
| 2 | MODEM | ACEEX | 1414V/3 | 0401008248 | IFAXDM1414 |
| 3 | PRINTER | EPSON | LQ-300+ | DCGY047265 | FCC DoC Approved |

| NO. | SIGNAL CABLE DESCRIPTION OF THE ABOVE SUPPORT UNITS |
|-----|---|
| 1 | NA |
| 2 | 1.2 m shielded cable without core |
| 3 | 1.2 m shielded cable without core |

NOTE: All power cords of the above support units are non shielded (1.8m).

4. TEST TYPES AND RESULTS

4.1 CONDUCTED EMISSION MEASUREMENT

4.1.1 LIMITS OF CONDUCTED EMISSION MEASUREMENT

| FREQUENCY OF EMISSION (MHz) | CONDUCTED LIMIT (dB μ V) | |
|-----------------------------|------------------------------|----------|
| | Quasi-peak | Average |
| 0.15 ~ 0.5 | 66 to 56 | 56 to 46 |
| 0.5 ~ 5 | 56 | 46 |
| 5 ~ 30 | 60 | 50 |

- NOTE:**
1. The lower limit shall apply at the transition frequencies.
 2. The limit decreases in line with the logarithm of the frequency in the range of 0.15 to 0.50 MHz.
 3. All emanations from a class A/B digital device or system, including any network of conductors and apparatus connected thereto, shall not exceed the level of field strengths specified above.

4.1.2 TEST INSTRUMENTS

| DESCRIPTION & MANUFACTURER | MODEL NO. | SERIAL NO. | CALIBRATED UNTIL |
|----------------------------------|-------------|----------------|------------------|
| Test Receiver ROHDE & SCHWARZ | ESCS30 | 100288 | Nov. 02, 2006 |
| RF signal cable Woken | 5D-FB | Cable-HYCO3-01 | Jan. 06, 2007 |
| LISN ROHDE & SCHWARZ | ESH2-Z5 | 100100 | Jan. 09, 2007 |
| LISN ROHDE & SCHWARZ | ESH3-Z5 | 100311 | Jan. 22, 2007 |
| Software ADT | ADT_Cond_V3 | NA | NA |

- NOTE:**
1. The calibration interval of the above test instruments is 12 months and the calibrations are traceable to NML/ROC and NIST/USA.
 2. The test was performed in HwaYa Shielded Room 2.
 3. The VCCI Site Registration No. is C-2047.

4.1.3 TEST PROCEDURES

- a. The EUT was placed 0.4 meters from the conducting wall of the shielded room with EUT being connected to the power mains through a line impedance stabilization network (LISN). Other support units were connected to the power mains through another LISN. The two LISNs provide 50 ohm/ 50uH of coupling impedance for the measuring instrument.
- b. Both lines of the power mains connected to the EUT were checked for maximum conducted interference.
- c. The frequency range from 150kHz to 30MHz was searched. Emission levels under (Limit - 20dB) was not recorded.

4.1.4 DEVIATION FROM TEST STANDARD

No deviation

4.1.5 TEST SETUP

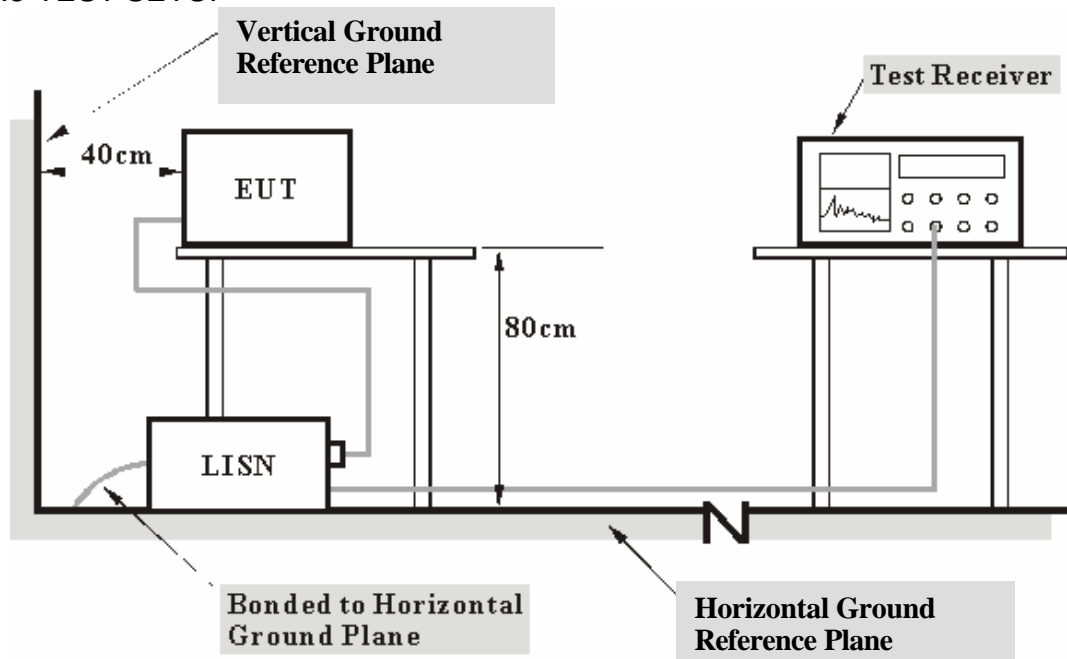

- Note:**
1. Support units were connected to second LISN.
 2. Both of LISNs (AMN) 80 cm from EUT and at the least 80 cm from other units and other metal planes support units.

For the actual test configuration, please refer to the attached file (Test Setup Photo).

4.1.6 EUT OPERATING CONDITIONS

TEST MODE A ~ D:

The EUT placed on the testing table and set it under transmission condition continuously at specific channel frequency.

TEST MODE E ~ G:

- a. Connected the EUT to a notebook system via USB cable and placed on a testing table.
- b. The notebook system ran a test program (provided by manufacturer) to enable EUT under transmission condition continuously at specific channel frequency.
- c. The necessary accessories enable the EUT in full functions

4.1.7 TEST RESULTS

CONDUCTED WORST CASE DATA:

| EUT TEST CONDITION | | MEASUREMENT DETAIL | |
|--------------------------|-------------------------|----------------------|---------------|
| CHANNEL | Channel 0 | PHASE | Line 1 |
| MODULATION TYPE | GFSK | 6dB BANDWIDTH | 9 kHz |
| ENVIRONMENTAL CONDITIONS | 23deg. C, 68%RH, 991hPa | INPUT POWER (SYSTEM) | 120Vac, 60 Hz |
| TEST MODE | A | TESTED BY | Match Tsui |

| No | Freq. [MHz] | Corr. Factor (dB) | Reading Value [dB (uV)] | | Emission Level [dB (uV)] | | Limit [dB (uV)] | | Margin (dB) | |
|----|-------------|-------------------|-------------------------|-------|--------------------------|-------|-----------------|-------|-------------|-------|
| | | | Q.P. | AV. | Q.P. | AV. | Q.P. | AV. | Q.P. | AV. |
| | | | 1 | 0.181 | 0.10 | 43.53 | - | 43.63 | - | 64.43 |
| 2 | 0.245 | 0.10 | 35.27 | - | 35.37 | - | 61.93 | 51.93 | -26.56 | - |
| 3 | 0.728 | 0.10 | 30.15 | - | 30.25 | - | 56.00 | 46.00 | -25.75 | - |
| 4 | 2.072 | 0.21 | 37.38 | - | 37.59 | - | 56.00 | 46.00 | -18.41 | - |
| 5 | 2.683 | 0.26 | 37.72 | - | 37.98 | - | 56.00 | 46.00 | -18.02 | - |
| 6 | 18.231 | 0.58 | 29.12 | - | 29.70 | - | 60.00 | 50.00 | -30.30 | - |

- REMARKS:**
1. Q.P. and AV. are abbreviations of quasi-peak and average individually.
 2. "-": The Quasi-peak reading value also meets average limit and measurement with the average detector is unnecessary.
 3. The emission levels of other frequencies were very low against the limit.
 4. Margin value = Emission level - Limit value
 5. Correction factor = Insertion loss + Cable loss
 6. Emission Level = Correction Factor + Reading Value.

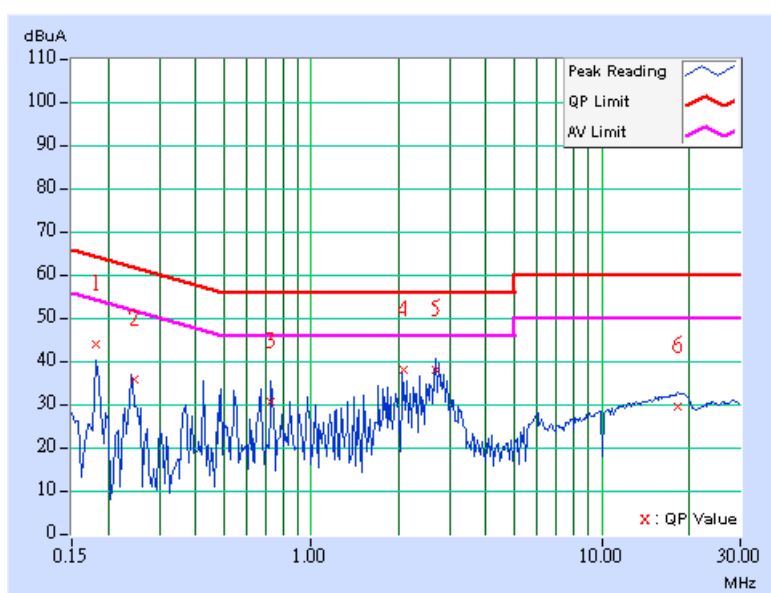

| EUT TEST CONDITION | | MEASUREMENT DETAIL | |
|--------------------------|-------------------------|----------------------|---------------|
| CHANNEL | Channel 0 | PHASE | Line 2 |
| MODULATION TYPE | GFSK | 6dB BANDWIDTH | 9 kHz |
| ENVIRONMENTAL CONDITIONS | 23deg. C, 68%RH, 991hPa | INPUT POWER (SYSTEM) | 120Vac, 60 Hz |
| TEST MODE | A | TESTED BY | Match Tsui |

| No | Freq. [MHz] | Corr. Factor [dB] | Reading Value [dB (uV)] | | Emission Level [dB (uV)] | | Limit [dB (uV)] | | Margin (dB) | |
|----|-------------|-------------------|-------------------------|-------|--------------------------|-------|-----------------|-------|-------------|-------|
| | | | Q.P. | AV. | Q.P. | AV. | Q.P. | AV. | Q.P. | AV. |
| | | | 1 | 0.181 | 0.10 | 35.44 | - | 35.54 | - | 64.43 |
| 2 | 0.244 | 0.10 | 34.29 | - | 34.39 | - | 61.97 | 51.97 | -27.58 | - |
| 3 | 0.423 | 0.10 | 32.43 | - | 32.53 | - | 57.38 | 47.38 | -24.85 | - |
| 4 | 0.789 | 0.16 | 30.18 | - | 30.34 | - | 56.00 | 46.00 | -25.66 | - |
| 5 | 2.551 | 0.25 | 32.00 | - | 32.25 | - | 56.00 | 46.00 | -23.75 | - |
| 6 | 18.859 | 0.58 | 29.69 | - | 30.27 | - | 60.00 | 50.00 | -29.73 | - |

- REMARKS:**
1. Q.P. and AV. are abbreviations of quasi-peak and average individually.
 2. "-": The Quasi-peak reading value also meets average limit and measurement with the average detector is unnecessary.
 3. The emission levels of other frequencies were very low against the limit.
 4. Margin value = Emission level - Limit value
 5. Correction factor = Insertion loss + Cable loss
 6. Emission Level = Correction Factor + Reading Value.

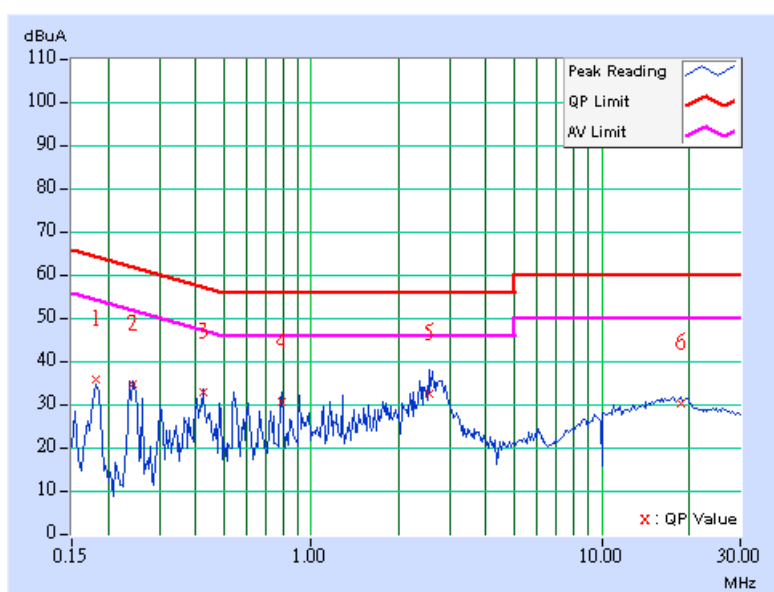

| EUT TEST CONDITION | | MEASUREMENT DETAIL | |
|--------------------------|-------------------------|----------------------|---------------|
| CHANNEL | Channel 39 | PHASE | Line 1 |
| MODULATION TYPE | GFSK | 6dB BANDWIDTH | 9 kHz |
| ENVIRONMENTAL CONDITIONS | 23deg. C, 68%RH, 991hPa | INPUT POWER (SYSTEM) | 120Vac, 60 Hz |
| TEST MODE | A | TESTED BY | Match Tsui |

| No | Freq. [MHz] | Corr. Factor [dB] | Reading Value [dB (uV)] | | Emission Level [dB (uV)] | | Limit [dB (uV)] | | Margin (dB) | |
|----|-------------|-------------------|-------------------------|-------|--------------------------|-------|-----------------|-------|-------------|-------|
| | | | Q.P. | AV. | Q.P. | AV. | Q.P. | AV. | Q.P. | AV. |
| | | | 1 | 0.181 | 0.10 | 39.41 | - | 39.51 | - | 64.43 |
| 2 | 0.244 | 0.10 | 32.84 | - | 32.94 | - | 61.97 | 51.97 | -29.03 | - |
| 3 | 0.611 | 0.10 | 34.89 | - | 34.99 | - | 56.00 | 46.00 | -21.01 | - |
| 4 | 1.098 | 0.11 | 33.98 | - | 34.09 | - | 56.00 | 46.00 | -21.91 | - |
| 5 | 2.195 | 0.22 | 39.00 | - | 39.22 | - | 56.00 | 46.00 | -16.78 | - |
| 6 | 17.056 | 0.60 | 31.10 | - | 31.70 | - | 60.00 | 50.00 | -28.30 | - |

- REMARKS:**
1. Q.P. and AV. are abbreviations of quasi-peak and average individually.
 2. "-": The Quasi-peak reading value also meets average limit and measurement with the average detector is unnecessary.
 3. The emission levels of other frequencies were very low against the limit.
 4. Margin value = Emission level - Limit value
 5. Correction factor = Insertion loss + Cable loss
 6. Emission Level = Correction Factor + Reading Value.

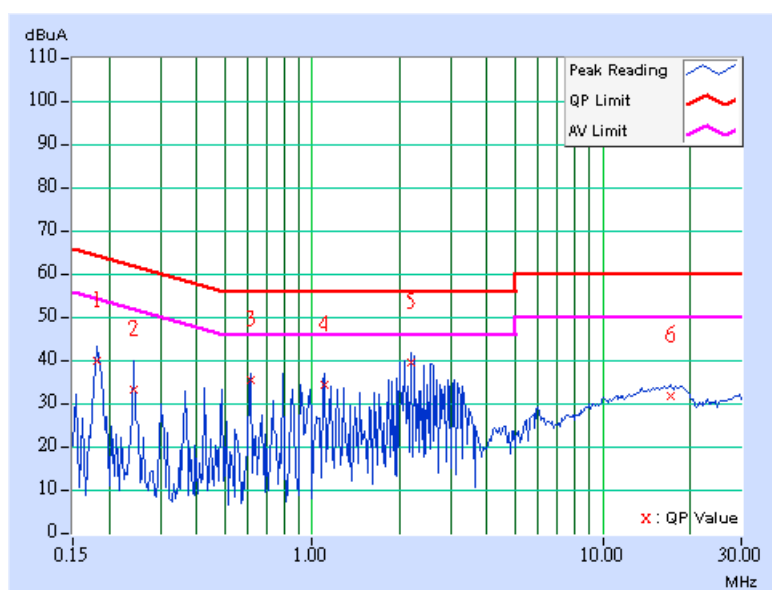

| EUT TEST CONDITION | | MEASUREMENT DETAIL | |
|--------------------------|-------------------------|----------------------|---------------|
| CHANNEL | Channel 39 | PHASE | Line 2 |
| MODULATION TYPE | GFSK | 6dB BANDWIDTH | 9 kHz |
| ENVIRONMENTAL CONDITIONS | 23deg. C, 68%RH, 991hPa | INPUT POWER (SYSTEM) | 120Vac, 60 Hz |
| TEST MODE | A | TESTED BY | Match Tsui |

| No | Freq. [MHz] | Corr. Factor [dB] | Reading Value [dB (uV)] | | Emission Level [dB (uV)] | | Limit [dB (uV)] | | Margin (dB) | |
|----|-------------|-------------------|-------------------------|-------|--------------------------|-------|-----------------|-------|-------------|-------|
| | | | Q.P. | AV. | Q.P. | AV. | Q.P. | AV. | Q.P. | AV. |
| | | | 1 | 0.185 | 0.10 | 40.04 | - | 40.14 | - | 64.25 |
| 2 | 0.244 | 0.10 | 33.79 | - | 33.89 | - | 61.97 | 51.97 | -28.08 | - |
| 3 | 0.486 | 0.11 | 33.84 | - | 33.95 | - | 56.24 | 46.24 | -22.28 | - |
| 4 | 0.853 | 0.18 | 34.14 | - | 34.32 | - | 56.00 | 46.00 | -21.68 | - |
| 5 | 2.316 | 0.23 | 37.80 | - | 38.03 | - | 56.00 | 46.00 | -17.97 | - |
| 6 | 16.698 | 0.61 | 30.88 | - | 31.49 | - | 60.00 | 50.00 | -28.51 | - |

- REMARKS:**
1. Q.P. and AV. are abbreviations of quasi-peak and average individually.
 2. "-": The Quasi-peak reading value also meets average limit and measurement with the average detector is unnecessary.
 3. The emission levels of other frequencies were very low against the limit.
 4. Margin value = Emission level - Limit value
 5. Correction factor = Insertion loss + Cable loss
 6. Emission Level = Correction Factor + Reading Value.

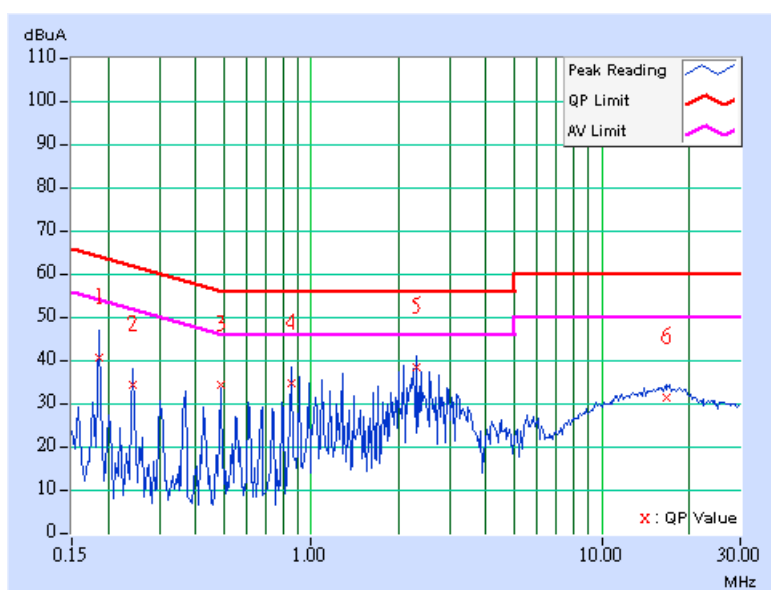

| EUT TEST CONDITION | | MEASUREMENT DETAIL | |
|--------------------------|-------------------------|----------------------|---------------|
| CHANNEL | Channel 78 | PHASE | Line 1 |
| MODULATION TYPE | GFSK | 6dB BANDWIDTH | 9 kHz |
| ENVIRONMENTAL CONDITIONS | 23deg. C, 68%RH, 991hPa | INPUT POWER (SYSTEM) | 120Vac, 60 Hz |
| TEST MODE | A | TESTED BY | Match Tsui |

| No | Freq. [MHz] | Corr. Factor [dB] | Reading Value [dB (uV)] | | Emission Level [dB (uV)] | | Limit [dB (uV)] | | Margin (dB) | |
|----|-------------|-------------------|-------------------------|-----|--------------------------|-----|-----------------|-------|-------------|-----|
| | | | Q.P. | AV. | Q.P. | AV. | Q.P. | AV. | Q.P. | AV. |
| | | | | | | | | | | |
| 1 | 0.181 | 0.10 | 38.31 | - | 38.41 | - | 64.43 | 54.43 | -26.02 | - |
| 2 | 0.306 | 0.10 | 29.07 | - | 29.17 | - | 60.07 | 50.07 | -30.90 | - |
| 3 | 0.611 | 0.10 | 34.12 | - | 34.22 | - | 56.00 | 46.00 | -21.78 | - |
| 4 | 1.156 | 0.12 | 33.36 | - | 33.48 | - | 56.00 | 46.00 | -22.52 | - |
| 5 | 2.680 | 0.26 | 36.02 | - | 36.28 | - | 56.00 | 46.00 | -19.72 | - |
| 6 | 16.680 | 0.61 | 30.72 | - | 31.33 | - | 60.00 | 50.00 | -28.67 | - |

- REMARKS:**
1. Q.P. and AV. are abbreviations of quasi-peak and average individually.
 2. "-": The Quasi-peak reading value also meets average limit and measurement with the average detector is unnecessary.
 3. The emission levels of other frequencies were very low against the limit.
 4. Margin value = Emission level - Limit value
 5. Correction factor = Insertion loss + Cable loss
 6. Emission Level = Correction Factor + Reading Value.

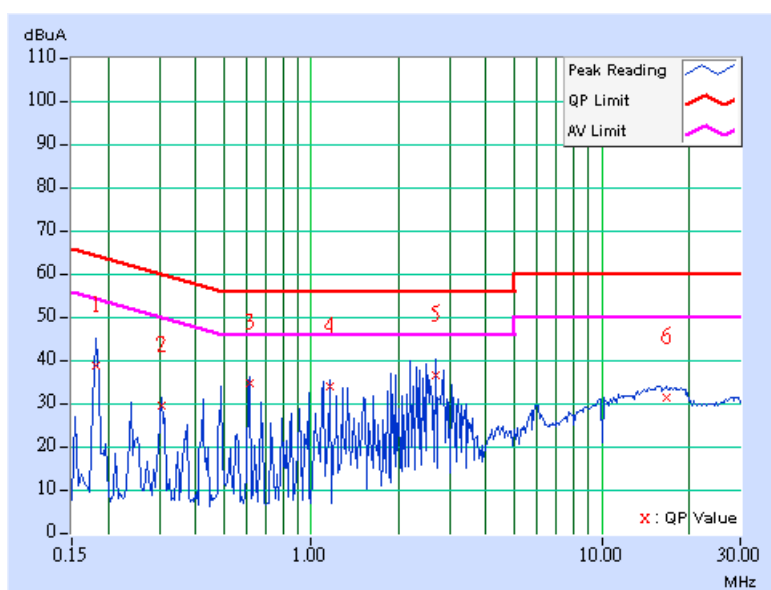

| EUT TEST CONDITION | | MEASUREMENT DETAIL | |
|--------------------------|-------------------------|----------------------|---------------|
| CHANNEL | Channel 78 | PHASE | Line 2 |
| MODULATION TYPE | GFSK | 6dB BANDWIDTH | 9 kHz |
| ENVIRONMENTAL CONDITIONS | 23deg. C, 68%RH, 991hPa | INPUT POWER (SYSTEM) | 120Vac, 60 Hz |
| TEST MODE | A | TESTED BY | Match Tsui |

| No | Freq. [MHz] | Corr. Factor [dB] | Reading Value [dB (uV)] | | Emission Level [dB (uV)] | | Limit [dB (uV)] | | Margin (dB) | |
|----|-------------|-------------------|-------------------------|-------|--------------------------|-------|-----------------|-------|-------------|-------|
| | | | Q.P. | AV. | Q.P. | AV. | Q.P. | AV. | Q.P. | AV. |
| | | | 1 | 0.185 | 0.10 | 37.96 | - | 38.06 | - | 64.25 |
| 2 | 0.244 | 0.10 | 32.08 | - | 32.18 | - | 61.97 | 51.97 | -29.79 | - |
| 3 | 0.489 | 0.11 | 34.39 | - | 34.50 | - | 56.19 | 46.19 | -21.69 | - |
| 4 | 1.277 | 0.20 | 32.90 | - | 33.10 | - | 56.00 | 46.00 | -22.90 | - |
| 5 | 2.617 | 0.25 | 36.33 | - | 36.58 | - | 56.00 | 46.00 | -19.42 | - |
| 6 | 16.566 | 0.61 | 29.31 | - | 29.92 | - | 60.00 | 50.00 | -30.08 | - |

- REMARKS:**
1. Q.P. and AV. are abbreviations of quasi-peak and average individually.
 2. "-": The Quasi-peak reading value also meets average limit and measurement with the average detector is unnecessary.
 3. The emission levels of other frequencies were very low against the limit.
 4. Margin value = Emission level - Limit value
 5. Correction factor = Insertion loss + Cable loss
 6. Emission Level = Correction Factor + Reading Value.

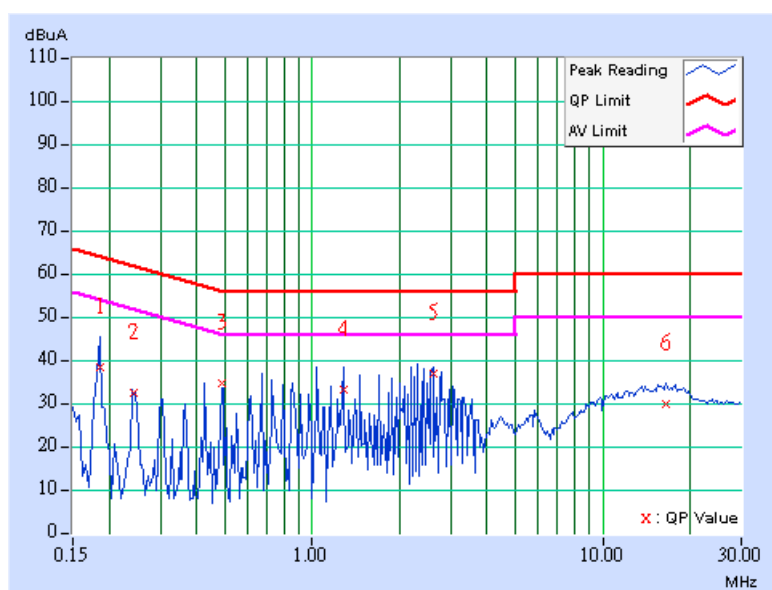

CONDUCTED WORST CASE DATA:

| EUT TEST CONDITION | | MEASUREMENT DETAIL | |
|--------------------------|-------------------------|----------------------|---------------|
| CHANNEL | Channel 0 | PHASE | Line 1 |
| MODULATION TYPE | GFSK | 6dB BANDWIDTH | 9 kHz |
| ENVIRONMENTAL CONDITIONS | 23deg. C, 68%RH, 991hPa | INPUT POWER (SYSTEM) | 120Vac, 60 Hz |
| TEST MODE | B | TESTED BY | Lori Chiu |

| No | Freq. [MHz] | Corr. Factor [dB] | Reading Value [dB (uV)] | | Emission Level [dB (uV)] | | Limit [dB (uV)] | | Margin (dB) | |
|----|-------------|-------------------|-------------------------|-----|--------------------------|-----|-----------------|-------|-------------|-----|
| | | | Q.P. | AV. | Q.P. | AV. | Q.P. | AV. | Q.P. | AV. |
| 1 | 0.314 | 0.10 | 39.50 | - | 39.60 | - | 59.86 | 49.86 | -20.26 | - |
| 2 | 0.400 | 0.10 | 47.55 | - | 47.65 | - | 57.86 | 47.86 | -10.21 | - |
| 3 | 0.529 | 0.10 | 38.60 | - | 38.70 | - | 56.00 | 46.00 | -17.30 | - |
| 4 | 0.927 | 0.10 | 35.90 | - | 36.00 | - | 56.00 | 46.00 | -20.00 | - |
| 5 | 2.430 | 0.24 | 32.73 | - | 32.97 | - | 56.00 | 46.00 | -23.03 | - |
| 6 | 8.293 | 0.36 | 34.40 | - | 34.76 | - | 60.00 | 50.00 | -25.24 | - |

- REMARKS:**
1. Q.P. and AV. are abbreviations of quasi-peak and average individually.
 2. "-": The Quasi-peak reading value also meets average limit and measurement with the average detector is unnecessary.
 3. The emission levels of other frequencies were very low against the limit.
 4. Margin value = Emission level - Limit value
 5. Correction factor = Insertion loss + Cable loss
 6. Emission Level = Correction Factor + Reading Value.

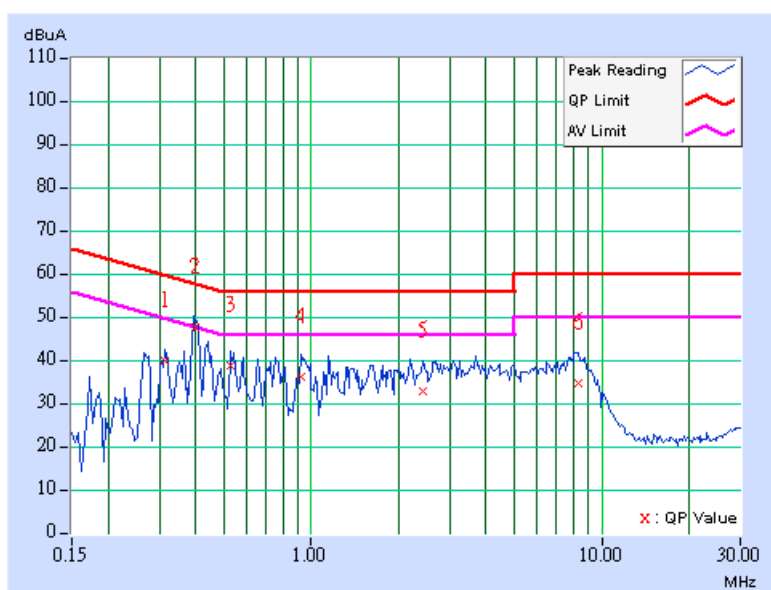

| EUT TEST CONDITION | | MEASUREMENT DETAIL | |
|--------------------------|-------------------------|----------------------|---------------|
| CHANNEL | Channel 0 | PHASE | Line 2 |
| MODULATION TYPE | GFSK | 6dB BANDWIDTH | 9 kHz |
| ENVIRONMENTAL CONDITIONS | 23deg. C, 68%RH, 991hPa | INPUT POWER (SYSTEM) | 120Vac, 60 Hz |
| TEST MODE | B | TESTED BY | Lori Chiu |

| No | Freq. [MHz] | Corr. Factor (dB) | Reading Value [dB (uV)] | | Emission Level [dB (uV)] | | Limit [dB (uV)] | | Margin (dB) | |
|----|-------------|-------------------|-------------------------|-------|--------------------------|-------|-----------------|-------|-------------|-------|
| | | | Q.P. | AV. | Q.P. | AV. | Q.P. | AV. | Q.P. | AV. |
| | | | 1 | 0.310 | 0.10 | 36.49 | - | 36.59 | - | 59.97 |
| 2 | 0.404 | 0.10 | 44.98 | - | 45.08 | - | 57.77 | 47.77 | -12.69 | - |
| 3 | 0.758 | 0.16 | 35.49 | - | 35.65 | - | 56.00 | 46.00 | -20.35 | - |
| 4 | 1.586 | 0.20 | 30.12 | - | 30.32 | - | 56.00 | 46.00 | -25.68 | - |
| 5 | 3.191 | 0.30 | 29.48 | - | 29.78 | - | 56.00 | 46.00 | -26.22 | - |
| 6 | 8.379 | 0.44 | 32.75 | - | 33.19 | - | 60.00 | 50.00 | -26.81 | - |

- REMARKS:**
1. Q.P. and AV. are abbreviations of quasi-peak and average individually.
 2. "-": The Quasi-peak reading value also meets average limit and measurement with the average detector is unnecessary.
 3. The emission levels of other frequencies were very low against the limit.
 4. Margin value = Emission level - Limit value
 5. Correction factor = Insertion loss + Cable loss
 6. Emission Level = Correction Factor + Reading Value.

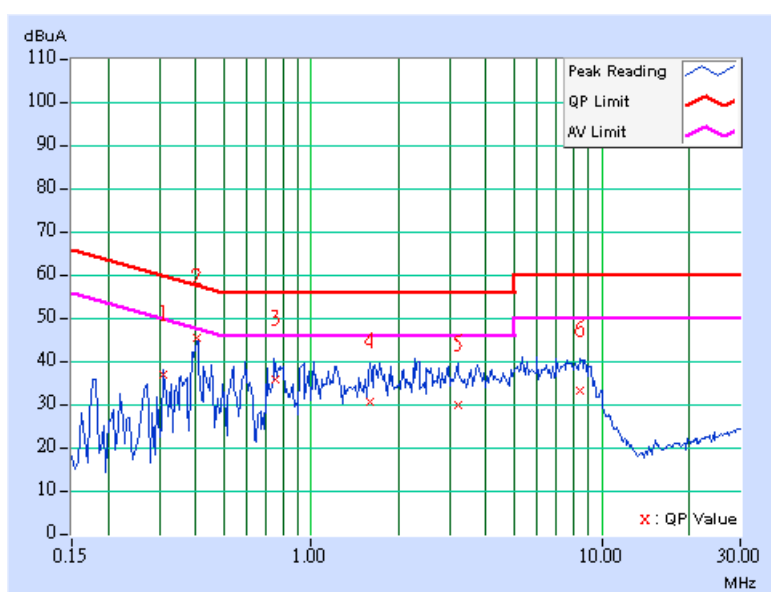

| EUT TEST CONDITION | | MEASUREMENT DETAIL | |
|--------------------------|-------------------------|----------------------|---------------|
| CHANNEL | Channel 39 | PHASE | Line 1 |
| MODULATION TYPE | GFSK | 6dB BANDWIDTH | 9 kHz |
| ENVIRONMENTAL CONDITIONS | 23deg. C, 68%RH, 991hPa | INPUT POWER (SYSTEM) | 120Vac, 60 Hz |
| TEST MODE | B | TESTED BY | Lori Chiu |

| No | Freq. [MHz] | Corr. Factor [dB] | Reading Value [dB (uV)] | | Emission Level [dB (uV)] | | Limit [dB (uV)] | | Margin (dB) | |
|----|-------------|-------------------|-------------------------|-------|--------------------------|-------|-----------------|-------|-------------|-------|
| | | | Q.P. | AV. | Q.P. | AV. | Q.P. | AV. | Q.P. | AV. |
| | | | 1 | 0.310 | 0.10 | 39.13 | - | 39.23 | - | 59.97 |
| 2 | 0.400 | 0.10 | 46.99 | - | 47.09 | - | 57.85 | 47.85 | -10.76 | - |
| 3 | 0.740 | 0.10 | 34.13 | - | 34.23 | - | 56.00 | 46.00 | -21.77 | - |
| 4 | 0.982 | 0.10 | 33.21 | - | 33.31 | - | 56.00 | 46.00 | -22.69 | - |
| 5 | 2.238 | 0.22 | 32.40 | - | 32.62 | - | 56.00 | 46.00 | -23.38 | - |
| 6 | 8.340 | 0.36 | 34.08 | - | 34.44 | - | 60.00 | 50.00 | -25.56 | - |

- REMARKS:**
1. Q.P. and AV. are abbreviations of quasi-peak and average individually.
 2. "-": The Quasi-peak reading value also meets average limit and measurement with the average detector is unnecessary.
 3. The emission levels of other frequencies were very low against the limit.
 4. Margin value = Emission level - Limit value
 5. Correction factor = Insertion loss + Cable loss
 6. Emission Level = Correction Factor + Reading Value.

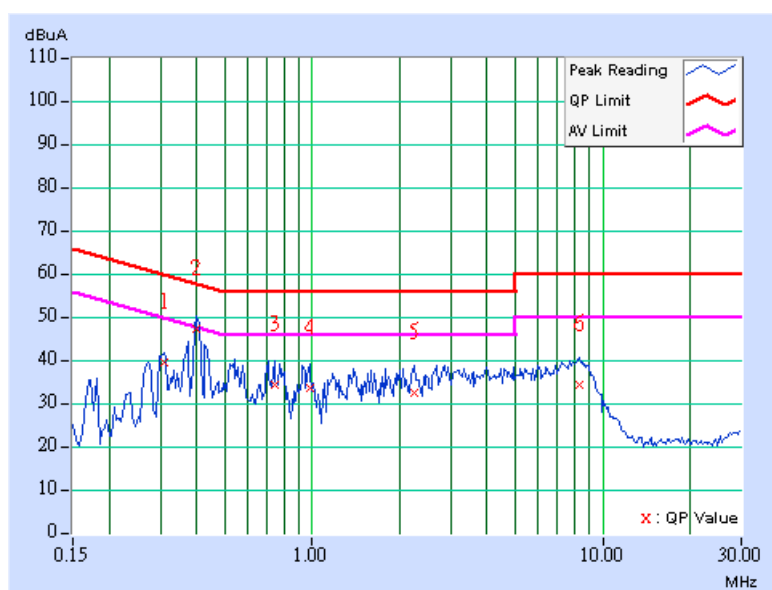

| EUT TEST CONDITION | | MEASUREMENT DETAIL | |
|--------------------------|-------------------------|----------------------|---------------|
| CHANNEL | Channel 39 | PHASE | Line 2 |
| MODULATION TYPE | GFSK | 6dB BANDWIDTH | 9 kHz |
| ENVIRONMENTAL CONDITIONS | 23deg. C, 68%RH, 991hPa | INPUT POWER (SYSTEM) | 120Vac, 60 Hz |
| TEST MODE | B | TESTED BY | Lori Chiu |

| No | Freq. [MHz] | Corr. Factor [dB] | Reading Value [dB (uV)] | | Emission Level [dB (uV)] | | Limit [dB (uV)] | | Margin (dB) | |
|----|-------------|-------------------|-------------------------|-------|--------------------------|-------|-----------------|-------|-------------|-------|
| | | | Q.P. | AV. | Q.P. | AV. | Q.P. | AV. | Q.P. | AV. |
| | | | 1 | 0.271 | 0.10 | 33.98 | - | 34.08 | - | 61.08 |
| 2 | 0.402 | 0.10 | 44.16 | - | 44.26 | - | 57.80 | 47.80 | -13.54 | - |
| 3 | 0.584 | 0.13 | 33.29 | - | 33.42 | - | 56.00 | 46.00 | -22.58 | - |
| 4 | 1.254 | 0.20 | 29.43 | - | 29.63 | - | 56.00 | 46.00 | -26.37 | - |
| 5 | 3.930 | 0.36 | 28.28 | - | 28.64 | - | 56.00 | 46.00 | -27.36 | - |
| 6 | 7.965 | 0.43 | 31.57 | - | 32.00 | - | 60.00 | 50.00 | -28.00 | - |

- REMARKS:**
1. Q.P. and AV. are abbreviations of quasi-peak and average individually.
 2. "-": The Quasi-peak reading value also meets average limit and measurement with the average detector is unnecessary.
 3. The emission levels of other frequencies were very low against the limit.
 4. Margin value = Emission level - Limit value
 5. Correction factor = Insertion loss + Cable loss
 6. Emission Level = Correction Factor + Reading Value.

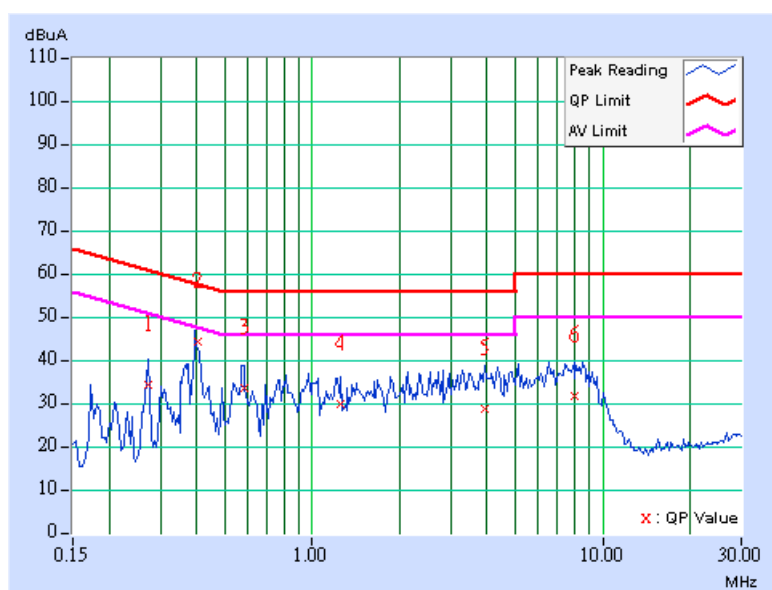

| EUT TEST CONDITION | | MEASUREMENT DETAIL | |
|--------------------------|-------------------------|----------------------|---------------|
| CHANNEL | Channel 78 | PHASE | Line 1 |
| MODULATION TYPE | GFSK | 6dB BANDWIDTH | 9 kHz |
| ENVIRONMENTAL CONDITIONS | 23deg. C, 68%RH, 991hPa | INPUT POWER (SYSTEM) | 120Vac, 60 Hz |
| TEST MODE | B | TESTED BY | Lori Chiu |

| No | Freq. | Corr. | Reading Value | | Emission Level | | Limit | | Margin | |
|----|-------|--------|---------------|-----|----------------|-----|-----------|-------|--------|-----|
| | [MHz] | Factor | [dB (uV)] | | [dB (uV)] | | [dB (uV)] | | (dB) | |
| | | (dB) | Q.P. | AV. | Q.P. | AV. | Q.P. | AV. | Q.P. | AV. |
| 1 | 0.314 | 0.10 | 38.17 | - | 38.27 | - | 59.86 | 49.86 | -21.59 | - |
| 2 | 0.405 | 0.10 | 46.22 | - | 46.32 | - | 57.74 | 47.74 | -11.42 | - |
| 3 | 0.529 | 0.10 | 37.25 | - | 37.35 | - | 56.00 | 46.00 | -18.65 | - |
| 4 | 1.152 | 0.12 | 32.81 | - | 32.93 | - | 56.00 | 46.00 | -23.07 | - |
| 5 | 2.852 | 0.27 | 31.67 | - | 31.94 | - | 56.00 | 46.00 | -24.06 | - |
| 6 | 8.566 | 0.36 | 33.62 | - | 33.98 | - | 60.00 | 50.00 | -26.02 | - |

- REMARKS:**
1. Q.P. and AV. are abbreviations of quasi-peak and average individually.
 2. "-": The Quasi-peak reading value also meets average limit and measurement with the average detector is unnecessary.
 3. The emission levels of other frequencies were very low against the limit.
 4. Margin value = Emission level - Limit value
 5. Correction factor = Insertion loss + Cable loss
 6. Emission Level = Correction Factor + Reading Value.

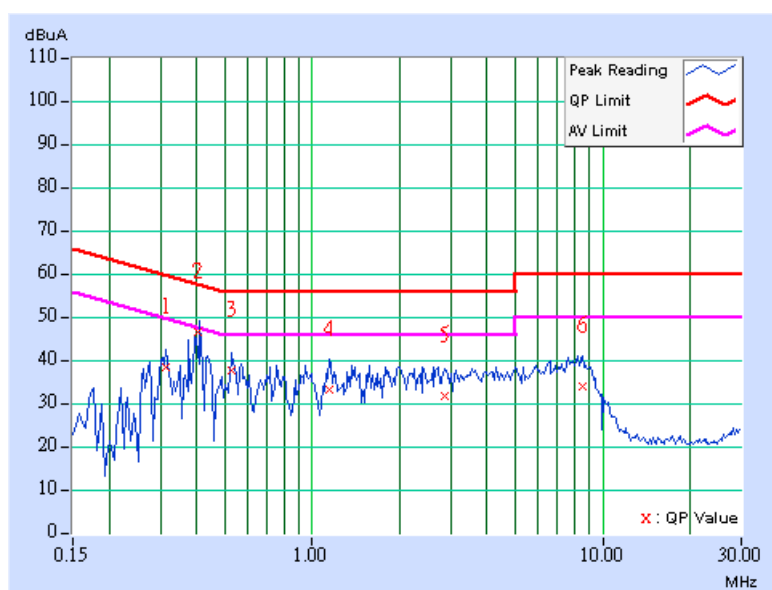

| EUT TEST CONDITION | | MEASUREMENT DETAIL | |
|--------------------------|-------------------------|----------------------|---------------|
| CHANNEL | Channel 78 | PHASE | Line 2 |
| MODULATION TYPE | GFSK | 6dB BANDWIDTH | 9 kHz |
| ENVIRONMENTAL CONDITIONS | 23deg. C, 68%RH, 991hPa | INPUT POWER (SYSTEM) | 120Vac, 60 Hz |
| TEST MODE | B | TESTED BY | Lori Chiu |

| No | Freq. [MHz] | Corr. Factor [dB] | Reading Value [dB (uV)] | | Emission Level [dB (uV)] | | Limit [dB (uV)] | | Margin (dB) | |
|----|-------------|-------------------|-------------------------|-------|--------------------------|-------|-----------------|-------|-------------|-------|
| | | | Q.P. | AV. | Q.P. | AV. | Q.P. | AV. | Q.P. | AV. |
| | | | 1 | 0.353 | 0.10 | 33.94 | - | 34.04 | - | 58.89 |
| 2 | 0.397 | 0.10 | 43.96 | - | 44.06 | - | 57.91 | 47.91 | -13.85 | - |
| 3 | 0.930 | 0.19 | 32.99 | - | 33.18 | - | 56.00 | 46.00 | -22.82 | - |
| 4 | 2.043 | 0.20 | 28.71 | - | 28.91 | - | 56.00 | 46.00 | -27.09 | - |
| 5 | 3.738 | 0.35 | 29.52 | - | 29.87 | - | 56.00 | 46.00 | -26.13 | - |
| 6 | 8.809 | 0.44 | 30.99 | - | 31.43 | - | 60.00 | 50.00 | -28.57 | - |

- REMARKS:**
1. Q.P. and AV. are abbreviations of quasi-peak and average individually.
 2. "-": The Quasi-peak reading value also meets average limit and measurement with the average detector is unnecessary.
 3. The emission levels of other frequencies were very low against the limit.
 4. Margin value = Emission level - Limit value
 5. Correction factor = Insertion loss + Cable loss
 6. Emission Level = Correction Factor + Reading Value.

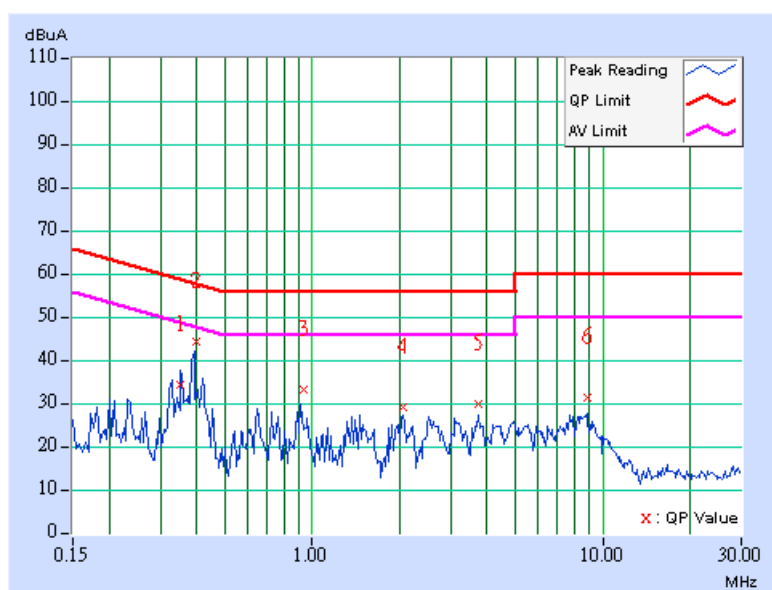

| EUT TEST CONDITION | | MEASUREMENT DETAIL | |
|--------------------------|-------------------------|----------------------|---------------|
| CHANNEL | Channel 0 | PHASE | Line 1 |
| MODULATION TYPE | GFSK | 6dB BANDWIDTH | 9 kHz |
| ENVIRONMENTAL CONDITIONS | 23deg. C, 68%RH, 991hPa | INPUT POWER (SYSTEM) | 120Vac, 60 Hz |
| TEST MODE | C | TESTED BY | Match Tsui |

| No | Freq. [MHz] | Corr. Factor (dB) | Reading Value [dB (uV)] | | Emission Level [dB (uV)] | | Limit [dB (uV)] | | Margin (dB) | |
|----|-------------|-------------------|-------------------------|-----|--------------------------|-----|-----------------|-------|-------------|-----|
| | | | Q.P. | AV. | Q.P. | AV. | Q.P. | AV. | Q.P. | AV. |
| 1 | 0.185 | 0.10 | 35.69 | - | 35.79 | - | 64.25 | 54.25 | -28.46 | - |
| 2 | 0.244 | 0.10 | 29.35 | - | 29.45 | - | 61.97 | 51.97 | -32.52 | - |
| 3 | 0.607 | 0.10 | 33.58 | - | 33.68 | - | 56.00 | 46.00 | -22.32 | - |
| 4 | 1.094 | 0.11 | 33.36 | - | 33.47 | - | 56.00 | 46.00 | -22.53 | - |
| 5 | 2.371 | 0.23 | 41.19 | - | 41.42 | - | 56.00 | 46.00 | -14.58 | - |
| 6 | 15.559 | 0.62 | 32.63 | - | 33.25 | - | 60.00 | 50.00 | -26.75 | - |

- REMARKS:**
1. Q.P. and AV. are abbreviations of quasi-peak and average individually.
 2. "-": The Quasi-peak reading value also meets average limit and measurement with the average detector is unnecessary.
 3. The emission levels of other frequencies were very low against the limit.
 4. Margin value = Emission level - Limit value
 5. Correction factor = Insertion loss + Cable loss
 6. Emission Level = Correction Factor + Reading Value.

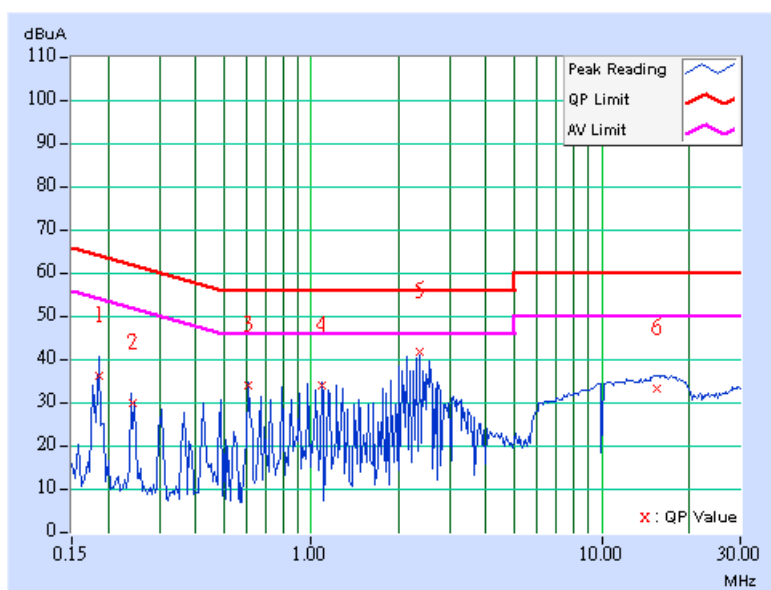

| EUT TEST CONDITION | | MEASUREMENT DETAIL | |
|--------------------------|-------------------------|----------------------|---------------|
| CHANNEL | Channel 0 | PHASE | Line 2 |
| MODULATION TYPE | GFSK | 6dB BANDWIDTH | 9 kHz |
| ENVIRONMENTAL CONDITIONS | 23deg. C, 68%RH, 991hPa | INPUT POWER (SYSTEM) | 120Vac, 60 Hz |
| TEST MODE | C | TESTED BY | Match Tsui |

| No | Freq. [MHz] | Corr. Factor [dB] | Reading Value [dB (uV)] | | Emission Level [dB (uV)] | | Limit [dB (uV)] | | Margin (dB) | |
|----|-------------|-------------------|-------------------------|-------|--------------------------|-------|-----------------|-------|-------------|-------|
| | | | Q.P. | AV. | Q.P. | AV. | Q.P. | AV. | Q.P. | AV. |
| | | | 1 | 0.182 | 0.10 | 36.98 | - | 37.08 | - | 64.37 |
| 2 | 0.244 | 0.10 | 30.53 | - | 30.63 | - | 61.97 | 51.97 | -31.34 | - |
| 3 | 0.668 | 0.14 | 31.11 | - | 31.25 | - | 56.00 | 46.00 | -24.75 | - |
| 4 | 1.034 | 0.20 | 31.21 | - | 31.41 | - | 56.00 | 46.00 | -24.59 | - |
| 5 | 2.188 | 0.22 | 39.04 | - | 39.26 | - | 56.00 | 46.00 | -16.74 | - |
| 6 | 15.376 | 0.62 | 33.84 | - | 34.46 | - | 60.00 | 50.00 | -25.54 | - |

- REMARKS:**
1. Q.P. and AV. are abbreviations of quasi-peak and average individually.
 2. "-": The Quasi-peak reading value also meets average limit and measurement with the average detector is unnecessary.
 3. The emission levels of other frequencies were very low against the limit.
 4. Margin value = Emission level - Limit value
 5. Correction factor = Insertion loss + Cable loss
 6. Emission Level = Correction Factor + Reading Value.

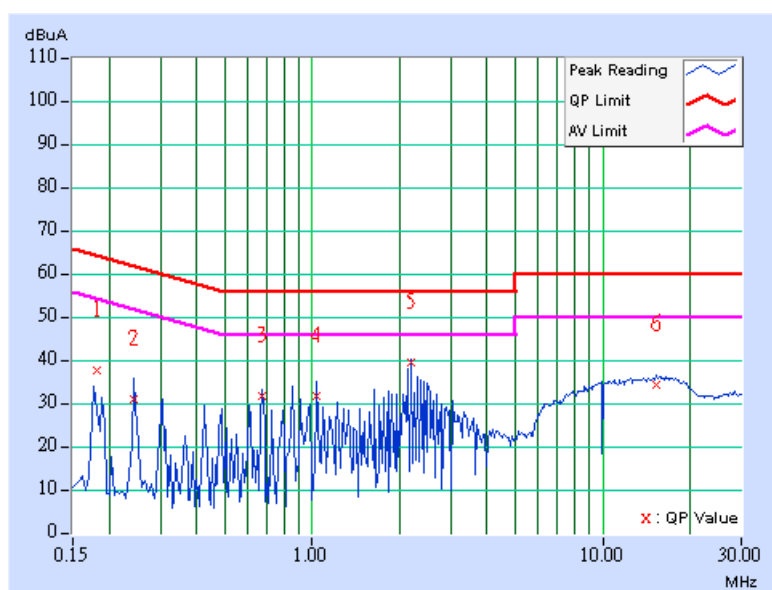

| EUT TEST CONDITION | | MEASUREMENT DETAIL | |
|--------------------------|-------------------------|----------------------|---------------|
| CHANNEL | Channel 39 | PHASE | Line 1 |
| MODULATION TYPE | GFSK | 6dB BANDWIDTH | 9 kHz |
| ENVIRONMENTAL CONDITIONS | 23deg. C, 68%RH, 991hPa | INPUT POWER (SYSTEM) | 120Vac, 60 Hz |
| TEST MODE | C | TESTED BY | Match Tsui |

| No | Freq. [MHz] | Corr. Factor [dB] | Reading Value [dB (uV)] | | Emission Level [dB (uV)] | | Limit [dB (uV)] | | Margin (dB) | |
|----|-------------|-------------------|-------------------------|-------|--------------------------|-------|-----------------|-------|-------------|-------|
| | | | Q.P. | AV. | Q.P. | AV. | Q.P. | AV. | Q.P. | AV. |
| | | | 1 | 0.182 | 0.10 | 36.35 | - | 36.45 | - | 64.37 |
| 2 | 0.306 | 0.10 | 26.82 | - | 26.92 | - | 60.07 | 50.07 | -33.15 | - |
| 3 | 0.607 | 0.10 | 33.60 | - | 33.70 | - | 56.00 | 46.00 | -22.30 | - |
| 4 | 0.970 | 0.10 | 33.77 | - | 33.87 | - | 56.00 | 46.00 | -22.13 | - |
| 5 | 2.371 | 0.23 | 40.95 | - | 41.18 | - | 56.00 | 46.00 | -14.82 | - |
| 6 | 16.586 | 0.61 | 33.34 | - | 33.95 | - | 60.00 | 50.00 | -26.05 | - |

- REMARKS:**
1. Q.P. and AV. are abbreviations of quasi-peak and average individually.
 2. "-": The Quasi-peak reading value also meets average limit and measurement with the average detector is unnecessary.
 3. The emission levels of other frequencies were very low against the limit.
 4. Margin value = Emission level - Limit value
 5. Correction factor = Insertion loss + Cable loss
 6. Emission Level = Correction Factor + Reading Value.

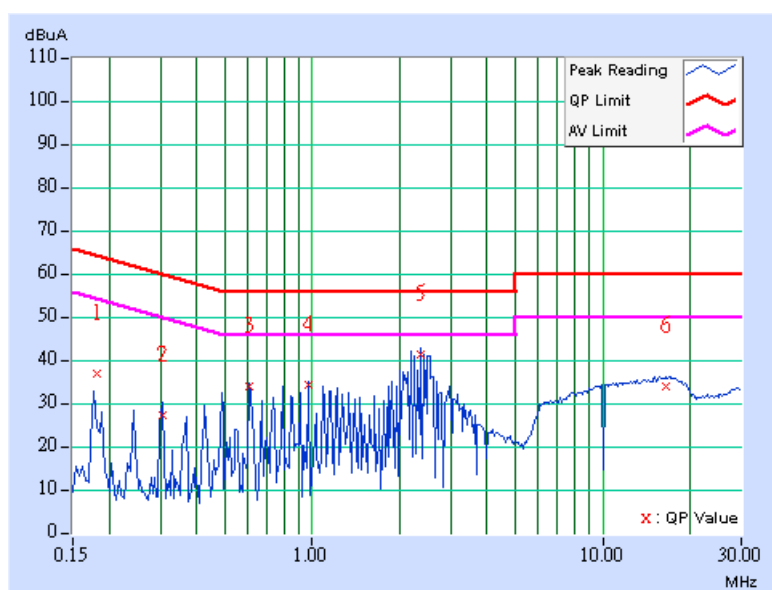

| EUT TEST CONDITION | | MEASUREMENT DETAIL | |
|--------------------------|-------------------------|----------------------|---------------|
| CHANNEL | Channel 39 | PHASE | Line 2 |
| MODULATION TYPE | GFSK | 6dB BANDWIDTH | 9 kHz |
| ENVIRONMENTAL CONDITIONS | 23deg. C, 68%RH, 991hPa | INPUT POWER (SYSTEM) | 120Vac, 60 Hz |
| TEST MODE | C | TESTED BY | Match Tsui |

| No | Freq. [MHz] | Corr. Factor [dB] | Reading Value [dB (uV)] | | Emission Level [dB (uV)] | | Limit [dB (uV)] | | Margin (dB) | |
|----|-------------|-------------------|-------------------------|-------|--------------------------|-------|-----------------|-------|-------------|-------|
| | | | Q.P. | AV. | Q.P. | AV. | Q.P. | AV. | Q.P. | AV. |
| | | | 1 | 0.185 | 0.10 | 35.50 | - | 35.60 | - | 64.25 |
| 2 | 0.240 | 0.10 | 28.29 | - | 28.39 | - | 62.10 | 52.10 | -33.71 | - |
| 3 | 0.487 | 0.11 | 31.64 | - | 31.75 | - | 56.22 | 46.22 | -24.46 | - |
| 4 | 1.277 | 0.20 | 29.64 | - | 29.84 | - | 56.00 | 46.00 | -26.16 | - |
| 5 | 2.246 | 0.22 | 37.65 | - | 37.87 | - | 56.00 | 46.00 | -18.13 | - |
| 6 | 17.984 | 0.59 | 32.99 | - | 33.58 | - | 60.00 | 50.00 | -26.42 | - |

- REMARKS:**
1. Q.P. and AV. are abbreviations of quasi-peak and average individually.
 2. "-": The Quasi-peak reading value also meets average limit and measurement with the average detector is unnecessary.
 3. The emission levels of other frequencies were very low against the limit.
 4. Margin value = Emission level - Limit value
 5. Correction factor = Insertion loss + Cable loss
 6. Emission Level = Correction Factor + Reading Value.

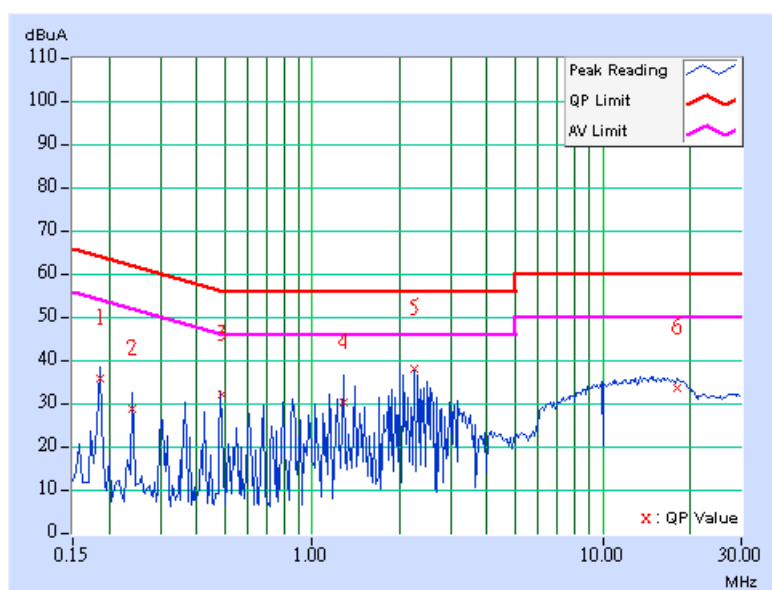

| EUT TEST CONDITION | | MEASUREMENT DETAIL | |
|--------------------------|-------------------------|----------------------|---------------|
| CHANNEL | Channel 78 | PHASE | Line 1 |
| MODULATION TYPE | GFSK | 6dB BANDWIDTH | 9 kHz |
| ENVIRONMENTAL CONDITIONS | 23deg. C, 68%RH, 991hPa | INPUT POWER (SYSTEM) | 120Vac, 60 Hz |
| TEST MODE | C | TESTED BY | Match Tsui |

| No | Freq. [MHz] | Corr. Factor [dB] | Reading Value [dB (uV)] | | Emission Level [dB (uV)] | | Limit [dB (uV)] | | Margin (dB) | |
|----|-------------|-------------------|-------------------------|-----|--------------------------|-----|-----------------|-------|-------------|-----|
| | | | Q.P. | AV. | Q.P. | AV. | Q.P. | AV. | Q.P. | AV. |
| | | | | | | | | | | |
| 1 | 0.181 | 0.10 | 35.75 | - | 35.85 | - | 64.43 | 54.43 | -28.58 | - |
| 2 | 0.302 | 0.10 | 27.74 | - | 27.84 | - | 60.18 | 50.18 | -32.34 | - |
| 3 | 0.607 | 0.10 | 33.58 | - | 33.68 | - | 56.00 | 46.00 | -22.32 | - |
| 4 | 1.215 | 0.12 | 28.10 | - | 28.22 | - | 56.00 | 46.00 | -27.78 | - |
| 5 | 2.246 | 0.22 | 39.21 | - | 39.43 | - | 56.00 | 46.00 | -16.57 | - |
| 6 | 16.219 | 0.61 | 33.57 | - | 34.18 | - | 60.00 | 50.00 | -25.82 | - |

- REMARKS:**
1. Q.P. and AV. are abbreviations of quasi-peak and average individually.
 2. "-": The Quasi-peak reading value also meets average limit and measurement with the average detector is unnecessary.
 3. The emission levels of other frequencies were very low against the limit.
 4. Margin value = Emission level - Limit value
 5. Correction factor = Insertion loss + Cable loss
 6. Emission Level = Correction Factor + Reading Value.

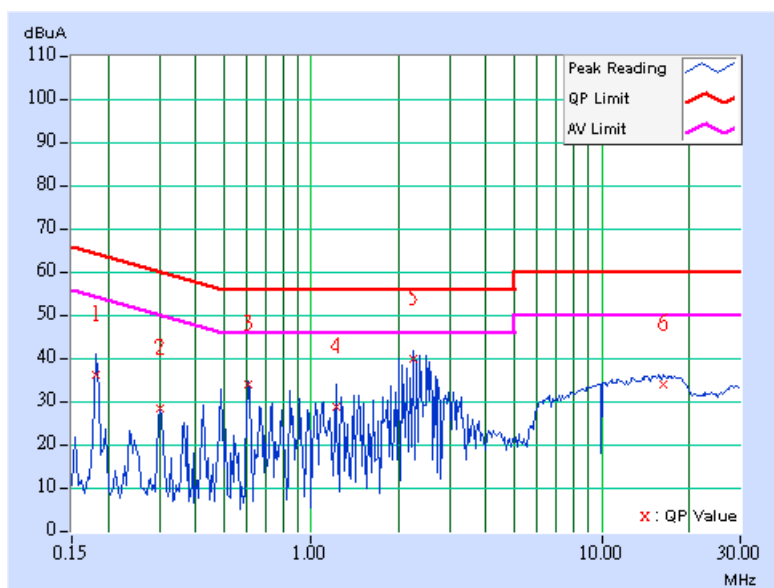

| EUT TEST CONDITION | | MEASUREMENT DETAIL | |
|--------------------------|-------------------------|----------------------|---------------|
| CHANNEL | Channel 78 | PHASE | Line 2 |
| MODULATION TYPE | GFSK | 6dB BANDWIDTH | 9 kHz |
| ENVIRONMENTAL CONDITIONS | 23deg. C, 68%RH, 991hPa | INPUT POWER (SYSTEM) | 120Vac, 60 Hz |
| TEST MODE | C | TESTED BY | Match Tsui |

| No | Freq. [MHz] | Corr. Factor [dB] | Reading Value [dB (uV)] | | Emission Level [dB (uV)] | | Limit [dB (uV)] | | Margin (dB) | |
|----|-------------|-------------------|-------------------------|-------|--------------------------|-------|-----------------|-------|-------------|-------|
| | | | Q.P. | AV. | Q.P. | AV. | Q.P. | AV. | Q.P. | AV. |
| | | | 1 | 0.181 | 0.10 | 35.83 | - | 35.93 | - | 64.43 |
| 2 | 0.302 | 0.10 | 25.91 | - | 26.01 | - | 60.18 | 50.18 | -34.17 | - |
| 3 | 0.853 | 0.18 | 31.30 | - | 31.48 | - | 56.00 | 46.00 | -24.52 | - |
| 4 | 1.219 | 0.20 | 29.83 | - | 30.03 | - | 56.00 | 46.00 | -25.97 | - |
| 5 | 2.371 | 0.23 | 39.14 | - | 39.37 | - | 56.00 | 46.00 | -16.63 | - |
| 6 | 15.734 | 0.62 | 33.64 | - | 34.26 | - | 60.00 | 50.00 | -25.74 | - |

- REMARKS:**
1. Q.P. and AV. are abbreviations of quasi-peak and average individually.
 2. "-": The Quasi-peak reading value also meets average limit and measurement with the average detector is unnecessary.
 3. The emission levels of other frequencies were very low against the limit.
 4. Margin value = Emission level - Limit value
 5. Correction factor = Insertion loss + Cable loss
 6. Emission Level = Correction Factor + Reading Value.

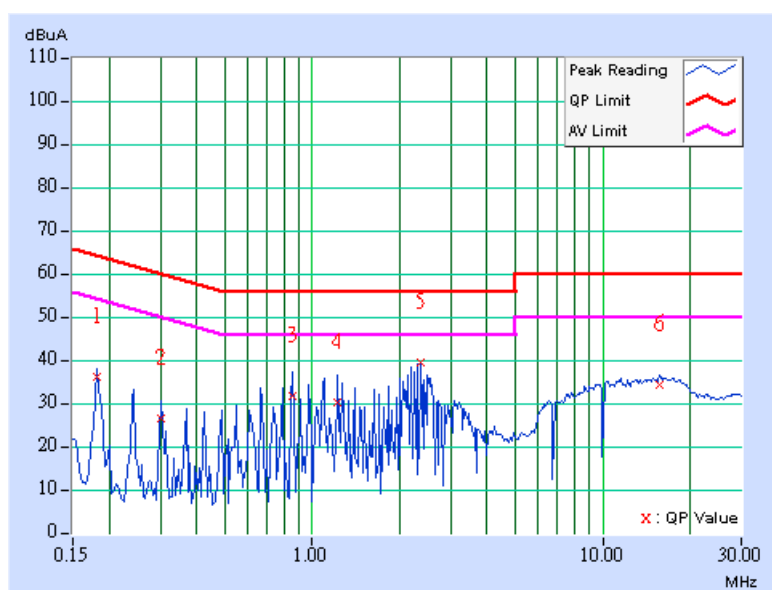

| EUT TEST CONDITION | | MEASUREMENT DETAIL | |
|--------------------------|-------------------------|----------------------|---------------|
| CHANNEL | Channel 0 | PHASE | Line 1 |
| MODULATION TYPE | GFSK | 6dB BANDWIDTH | 9 kHz |
| ENVIRONMENTAL CONDITIONS | 23deg. C, 68%RH, 991hPa | INPUT POWER (SYSTEM) | 120Vac, 60 Hz |
| TEST MODE | D | TESTED BY | Match Tsui |

| No | Freq. [MHz] | Corr. Factor [dB] | Reading Value [dB (uV)] | | Emission Level [dB (uV)] | | Limit [dB (uV)] | | Margin (dB) | |
|----|-------------|-------------------|-------------------------|-----|--------------------------|-----|-----------------|-------|-------------|-----|
| | | | Q.P. | AV. | Q.P. | AV. | Q.P. | AV. | Q.P. | AV. |
| | | | | | | | | | | |
| 1 | 0.412 | 0.10 | 44.27 | - | 44.37 | - | 57.61 | 47.61 | -13.24 | - |
| 2 | 0.541 | 0.10 | 43.85 | - | 43.95 | - | 56.00 | 46.00 | -12.05 | - |
| 3 | 1.195 | 0.12 | 40.49 | - | 40.61 | - | 56.00 | 46.00 | -15.39 | - |
| 4 | 2.348 | 0.23 | 38.65 | - | 38.88 | - | 56.00 | 46.00 | -17.12 | - |
| 5 | 3.656 | 0.34 | 39.00 | - | 39.34 | - | 56.00 | 46.00 | -16.66 | - |
| 6 | 7.695 | 0.36 | 40.63 | - | 40.99 | - | 60.00 | 50.00 | -19.01 | - |

- REMARKS:**
1. Q.P. and AV. are abbreviations of quasi-peak and average individually.
 2. "-": The Quasi-peak reading value also meets average limit and measurement with the average detector is unnecessary.
 3. The emission levels of other frequencies were very low against the limit.
 4. Margin value = Emission level - Limit value
 5. Correction factor = Insertion loss + Cable loss
 6. Emission Level = Correction Factor + Reading Value.

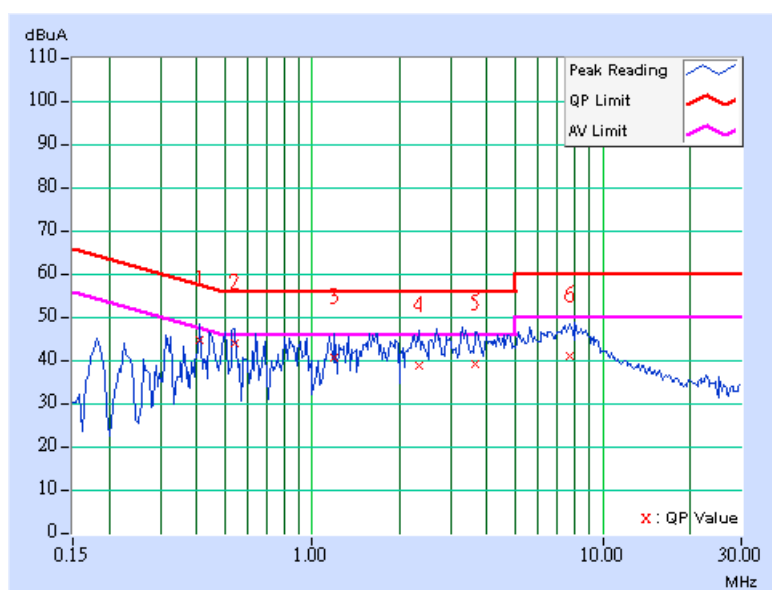

| EUT TEST CONDITION | | MEASUREMENT DETAIL | |
|--------------------------|-------------------------|----------------------|---------------|
| CHANNEL | Channel 0 | PHASE | Line 2 |
| MODULATION TYPE | GFSK | 6dB BANDWIDTH | 9 kHz |
| ENVIRONMENTAL CONDITIONS | 23deg. C, 68%RH, 991hPa | INPUT POWER (SYSTEM) | 120Vac, 60 Hz |
| TEST MODE | D | TESTED BY | Match Tsui |

| No | Freq. [MHz] | Corr. Factor [dB] | Reading Value [dB (uV)] | | Emission Level [dB (uV)] | | Limit [dB (uV)] | | Margin (dB) | |
|----|-------------|-------------------|-------------------------|-------|--------------------------|-------|-----------------|-------|-------------|-------|
| | | | Q.P. | AV. | Q.P. | AV. | Q.P. | AV. | Q.P. | AV. |
| | | | 1 | 0.315 | 0.10 | 41.06 | - | 41.16 | - | 59.83 |
| 2 | 0.455 | 0.11 | 38.78 | - | 38.89 | - | 56.79 | 46.79 | -17.90 | - |
| 3 | 1.184 | 0.20 | 38.67 | - | 38.87 | - | 56.00 | 46.00 | -17.13 | - |
| 4 | 2.270 | 0.22 | 36.52 | - | 36.74 | - | 56.00 | 46.00 | -19.26 | - |
| 5 | 4.480 | 0.38 | 35.37 | - | 35.75 | - | 56.00 | 46.00 | -20.25 | - |
| 6 | 7.934 | 0.43 | 36.50 | - | 36.93 | - | 60.00 | 50.00 | -23.07 | - |

- REMARKS:**
1. Q.P. and AV. are abbreviations of quasi-peak and average individually.
 2. "-": The Quasi-peak reading value also meets average limit and measurement with the average detector is unnecessary.
 3. The emission levels of other frequencies were very low against the limit.
 4. Margin value = Emission level - Limit value
 5. Correction factor = Insertion loss + Cable loss
 6. Emission Level = Correction Factor + Reading Value.

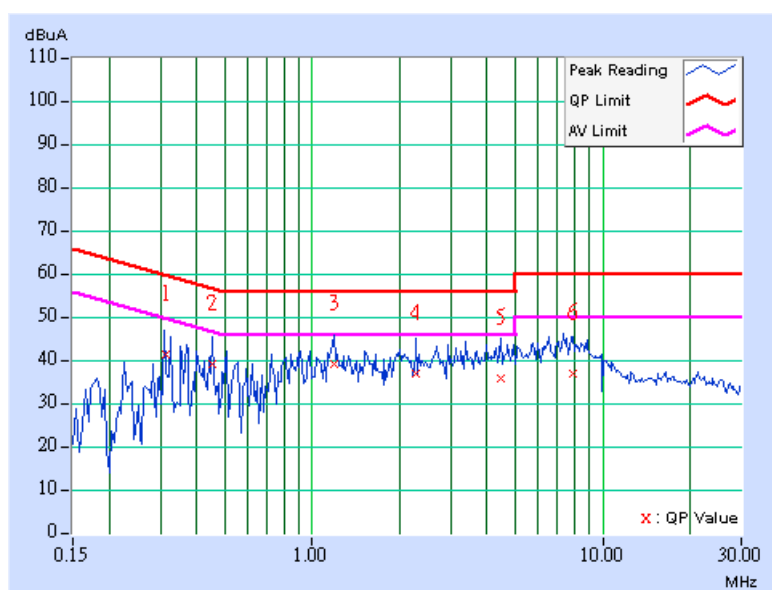

| EUT TEST CONDITION | | MEASUREMENT DETAIL | |
|--------------------------|-------------------------|----------------------|---------------|
| CHANNEL | Channel 39 | PHASE | Line 1 |
| MODULATION TYPE | GFSK | 6dB BANDWIDTH | 9 kHz |
| ENVIRONMENTAL CONDITIONS | 23deg. C, 68%RH, 991hPa | INPUT POWER (SYSTEM) | 120Vac, 60 Hz |
| TEST MODE | D | TESTED BY | Match Tsui |

| No | Freq. [MHz] | Corr. Factor [dB] | Reading Value [dB (uV)] | | Emission Level [dB (uV)] | | Limit [dB (uV)] | | Margin (dB) | |
|----|-------------|-------------------|-------------------------|-------|--------------------------|-------|-----------------|-------|-------------|-------|
| | | | Q.P. | AV. | Q.P. | AV. | Q.P. | AV. | Q.P. | AV. |
| | | | 1 | 0.408 | 0.10 | 44.22 | - | 44.32 | - | 57.69 |
| 2 | 0.634 | 0.10 | 41.27 | - | 41.37 | - | 56.00 | 46.00 | -14.63 | - |
| 3 | 0.896 | 0.10 | 40.06 | - | 40.16 | - | 56.00 | 46.00 | -15.84 | - |
| 4 | 1.559 | 0.16 | 39.59 | - | 39.75 | - | 56.00 | 46.00 | -16.25 | - |
| 5 | 3.723 | 0.35 | 39.26 | - | 39.61 | - | 56.00 | 46.00 | -16.39 | - |
| 6 | 8.672 | 0.36 | 41.54 | - | 41.90 | - | 60.00 | 50.00 | -18.10 | - |

- REMARKS:**
1. Q.P. and AV. are abbreviations of quasi-peak and average individually.
 2. "-": The Quasi-peak reading value also meets average limit and measurement with the average detector is unnecessary.
 3. The emission levels of other frequencies were very low against the limit.
 4. Margin value = Emission level - Limit value
 5. Correction factor = Insertion loss + Cable loss
 6. Emission Level = Correction Factor + Reading Value.

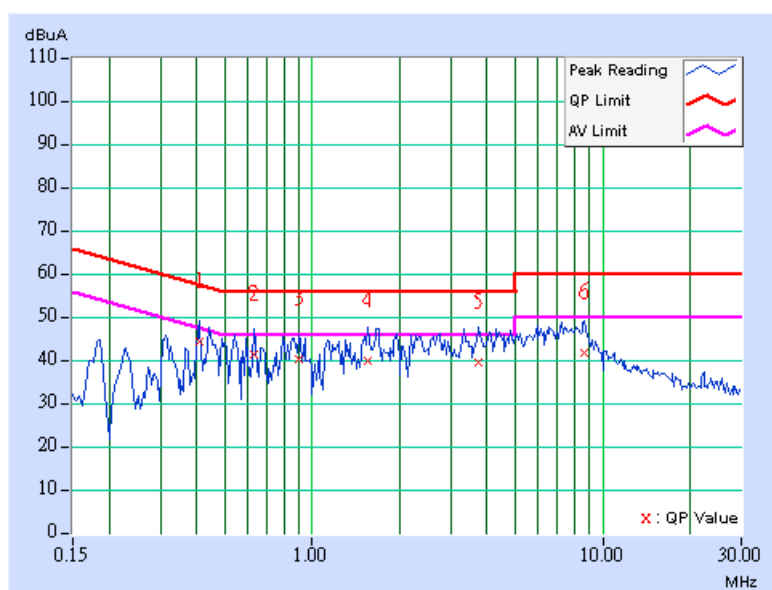

| EUT TEST CONDITION | | MEASUREMENT DETAIL | |
|--------------------------|-------------------------|----------------------|---------------|
| CHANNEL | Channel 39 | PHASE | Line 1 |
| MODULATION TYPE | GFSK | 6dB BANDWIDTH | 9 kHz |
| ENVIRONMENTAL CONDITIONS | 23deg. C, 68%RH, 991hPa | INPUT POWER (SYSTEM) | 120Vac, 60 Hz |
| TEST MODE | D | TESTED BY | Match Tsui |

| No | Freq. [MHz] | Corr. Factor [dB] | Reading Value [dB (uV)] | | Emission Level [dB (uV)] | | Limit [dB (uV)] | | Margin (dB) | |
|----|-------------|-------------------|-------------------------|-------|--------------------------|-------|-----------------|-------|-------------|-------|
| | | | Q.P. | AV. | Q.P. | AV. | Q.P. | AV. | Q.P. | AV. |
| | | | 1 | 0.427 | 0.10 | 36.16 | - | 36.26 | - | 57.30 |
| 2 | 0.814 | 0.17 | 36.19 | - | 36.36 | - | 56.00 | 46.00 | -19.64 | - |
| 3 | 1.172 | 0.20 | 39.44 | - | 39.64 | - | 56.00 | 46.00 | -16.36 | - |
| 4 | 2.695 | 0.26 | 36.20 | - | 36.46 | - | 56.00 | 46.00 | -19.54 | - |
| 5 | 4.859 | 0.38 | 36.48 | - | 36.86 | - | 56.00 | 46.00 | -19.14 | - |
| 6 | 8.707 | 0.44 | 36.56 | - | 37.00 | - | 60.00 | 50.00 | -23.00 | - |

- REMARKS:**
1. Q.P. and AV. are abbreviations of quasi-peak and average individually.
 2. "-": The Quasi-peak reading value also meets average limit and measurement with the average detector is unnecessary.
 3. The emission levels of other frequencies were very low against the limit.
 4. Margin value = Emission level - Limit value
 5. Correction factor = Insertion loss + Cable loss
 6. Emission Level = Correction Factor + Reading Value.

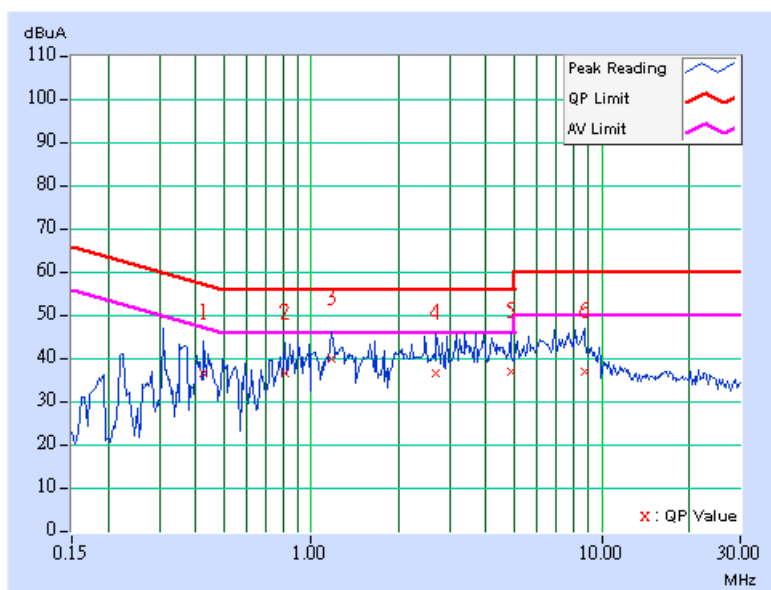

| EUT TEST CONDITION | | MEASUREMENT DETAIL | |
|--------------------------|-------------------------|----------------------|---------------|
| CHANNEL | Channel 78 | PHASE | Line 1 |
| MODULATION TYPE | GFSK | 6dB BANDWIDTH | 9 kHz |
| ENVIRONMENTAL CONDITIONS | 23deg. C, 68%RH, 991hPa | INPUT POWER (SYSTEM) | 120Vac, 60 Hz |
| TEST MODE | D | TESTED BY | Match Tsui |

| No | Freq. [MHz] | Corr. Factor [dB] | Reading Value [dB (uV)] | | Emission Level [dB (uV)] | | Limit [dB (uV)] | | Margin (dB) | |
|----|-------------|-------------------|-------------------------|-------|--------------------------|-------|-----------------|-------|-------------|-------|
| | | | Q.P. | AV. | Q.P. | AV. | Q.P. | AV. | Q.P. | AV. |
| | | | 1 | 0.408 | 0.10 | 44.22 | - | 44.32 | - | 57.69 |
| 2 | 0.541 | 0.10 | 43.73 | - | 43.83 | - | 56.00 | 46.00 | -12.17 | - |
| 3 | 0.845 | 0.10 | 41.81 | - | 41.91 | - | 56.00 | 46.00 | -14.09 | - |
| 4 | 1.652 | 0.17 | 39.70 | - | 39.87 | - | 56.00 | 46.00 | -16.13 | - |
| 5 | 3.359 | 0.32 | 39.87 | - | 40.19 | - | 56.00 | 46.00 | -15.81 | - |
| 6 | 8.434 | 0.36 | 41.35 | - | 41.71 | - | 60.00 | 50.00 | -18.29 | - |

- REMARKS:**
1. Q.P. and AV. are abbreviations of quasi-peak and average individually.
 2. "-": The Quasi-peak reading value also meets average limit and measurement with the average detector is unnecessary.
 3. The emission levels of other frequencies were very low against the limit.
 4. Margin value = Emission level - Limit value
 5. Correction factor = Insertion loss + Cable loss
 6. Emission Level = Correction Factor + Reading Value.

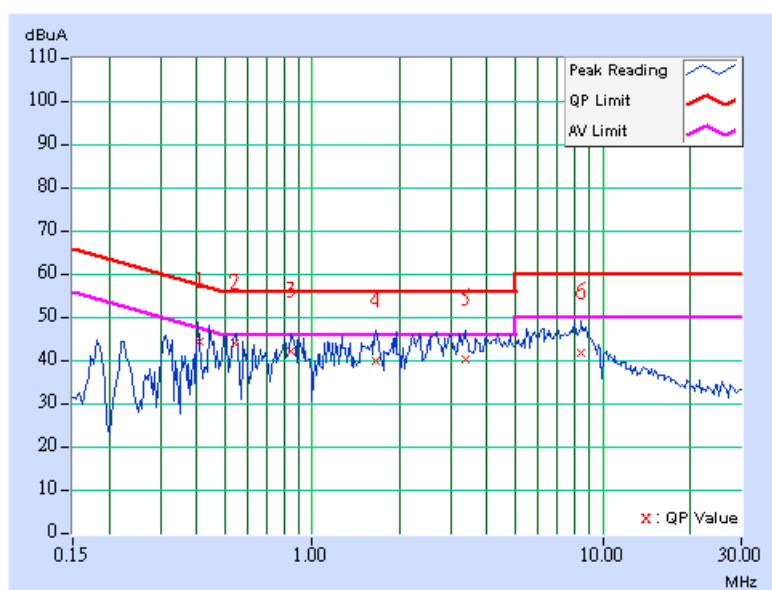

| EUT TEST CONDITION | | MEASUREMENT DETAIL | |
|--------------------------|-------------------------|----------------------|---------------|
| CHANNEL | Channel 78 | PHASE | Line 2 |
| MODULATION TYPE | GFSK | 6dB BANDWIDTH | 9 kHz |
| ENVIRONMENTAL CONDITIONS | 23deg. C, 68%RH, 991hPa | INPUT POWER (SYSTEM) | 120Vac, 60 Hz |
| TEST MODE | D | TESTED BY | Match Tsui |

| No | Freq. [MHz] | Corr. Factor [dB] | Reading Value [dB (uV)] | | Emission Level [dB (uV)] | | Limit [dB (uV)] | | Margin (dB) | |
|----|-------------|-------------------|-------------------------|-------|--------------------------|-------|-----------------|-------|-------------|-------|
| | | | Q.P. | AV. | Q.P. | AV. | Q.P. | AV. | Q.P. | AV. |
| | | | 1 | 0.357 | 0.10 | 41.07 | - | 41.17 | - | 58.80 |
| 2 | 0.500 | 0.12 | 38.40 | - | 38.52 | - | 56.00 | 46.00 | -17.48 | - |
| 3 | 1.172 | 0.20 | 39.29 | - | 39.49 | - | 56.00 | 46.00 | -16.51 | - |
| 4 | 2.582 | 0.25 | 36.09 | - | 36.34 | - | 56.00 | 46.00 | -19.66 | - |
| 5 | 4.207 | 0.37 | 34.51 | - | 34.88 | - | 56.00 | 46.00 | -21.12 | - |
| 6 | 8.211 | 0.43 | 37.73 | - | 38.16 | - | 60.00 | 50.00 | -21.84 | - |

- REMARKS:**
1. Q.P. and AV. are abbreviations of quasi-peak and average individually.
 2. "-": The Quasi-peak reading value also meets average limit and measurement with the average detector is unnecessary.
 3. The emission levels of other frequencies were very low against the limit.
 4. Margin value = Emission level - Limit value
 5. Correction factor = Insertion loss + Cable loss
 6. Emission Level = Correction Factor + Reading Value.

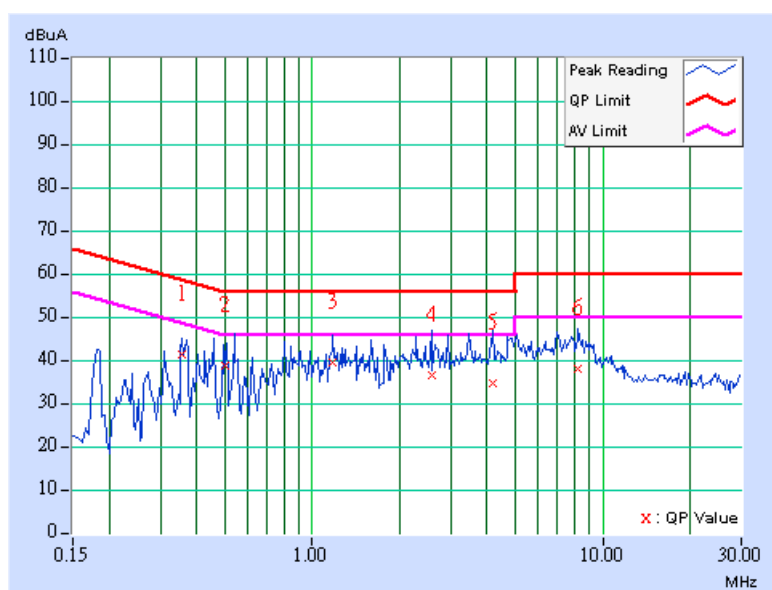

| EUT TEST CONDITION | | MEASUREMENT DETAIL | |
|--------------------------|-------------------------|----------------------|---------------|
| CHANNEL | Channel 0 | PHASE | Line 1 |
| MODULATION TYPE | GFSK | 6dB BANDWIDTH | 9 kHz |
| ENVIRONMENTAL CONDITIONS | 23deg. C, 68%RH, 991hPa | INPUT POWER (SYSTEM) | 120Vac, 60 Hz |
| TEST MODE | E | TESTED BY | Match Tsui |

| No | Freq. [MHz] | Corr. Factor [dB] | Reading Value [dB (uV)] | | Emission Level [dB (uV)] | | Limit [dB (uV)] | | Margin [dB] | |
|----|-------------|-------------------|-------------------------|-----|--------------------------|-----|-----------------|-------|-------------|-----|
| | | | Q.P. | AV. | Q.P. | AV. | Q.P. | AV. | Q.P. | AV. |
| 1 | 0.220 | 0.10 | 44.16 | - | 44.26 | - | 62.81 | 52.81 | -18.55 | - |
| 2 | 0.326 | 0.10 | 33.82 | - | 33.92 | - | 59.56 | 49.56 | -25.64 | - |
| 3 | 0.447 | 0.10 | 27.47 | - | 27.57 | - | 56.93 | 46.93 | -29.36 | - |
| 4 | 0.673 | 0.10 | 27.55 | - | 27.65 | - | 56.00 | 46.00 | -28.35 | - |
| 5 | 2.086 | 0.21 | 25.38 | - | 25.59 | - | 56.00 | 46.00 | -30.41 | - |
| 6 | 9.180 | 0.36 | 22.06 | - | 22.42 | - | 60.00 | 50.00 | -37.58 | - |

- REMARKS:**
1. Q.P. and AV. are abbreviations of quasi-peak and average individually.
 2. "-": The Quasi-peak reading value also meets average limit and measurement with the average detector is unnecessary.
 3. The emission levels of other frequencies were very low against the limit.
 4. Margin value = Emission level - Limit value
 5. Correction factor = Insertion loss + Cable loss
 6. Emission Level = Correction Factor + Reading Value.

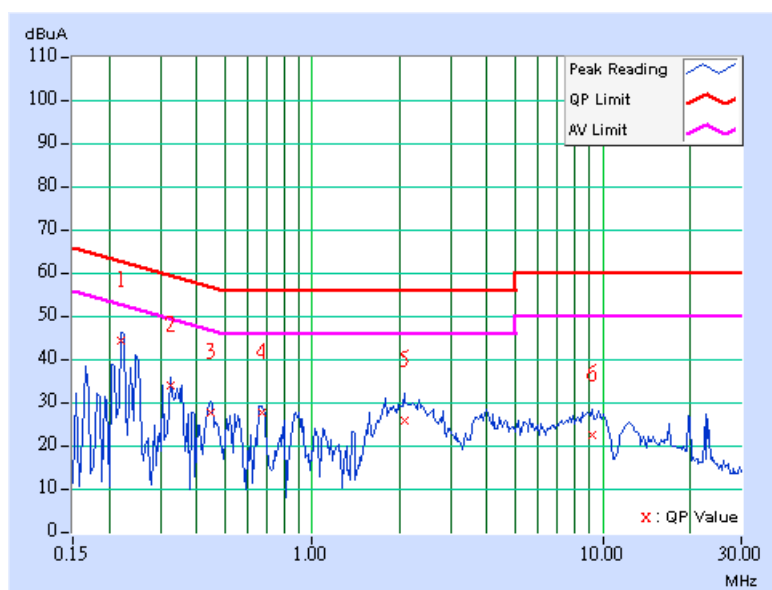

| EUT TEST CONDITION | | MEASUREMENT DETAIL | |
|--------------------------|-------------------------|----------------------|---------------|
| CHANNEL | Channel 0 | PHASE | Line 2 |
| MODULATION TYPE | GFSK | 6dB BANDWIDTH | 9 kHz |
| ENVIRONMENTAL CONDITIONS | 23deg. C, 68%RH, 991hPa | INPUT POWER (SYSTEM) | 120Vac, 60 Hz |
| TEST MODE | E | TESTED BY | Match Tsui |

| No | Freq. [MHz] | Corr. Factor [dB] | Reading Value [dB (uV)] | | Emission Level [dB (uV)] | | Limit [dB (uV)] | | Margin (dB) | |
|----|-------------|-------------------|-------------------------|-----|--------------------------|-----|-----------------|-------|-------------|-----|
| | | | Q.P. | AV. | Q.P. | AV. | Q.P. | AV. | Q.P. | AV. |
| 1 | 0.150 | 0.10 | 42.94 | - | 43.04 | - | 66.00 | 56.00 | -22.96 | - |
| 2 | 0.213 | 0.10 | 42.25 | - | 42.35 | - | 63.11 | 53.11 | -20.76 | - |
| 3 | 0.330 | 0.10 | 33.32 | - | 33.42 | - | 59.46 | 49.46 | -26.04 | - |
| 4 | 0.662 | 0.14 | 29.05 | - | 29.19 | - | 56.00 | 46.00 | -26.81 | - |
| 5 | 2.195 | 0.22 | 24.64 | - | 24.86 | - | 56.00 | 46.00 | -31.14 | - |
| 6 | 12.020 | 0.53 | 21.86 | - | 22.39 | - | 60.00 | 50.00 | -37.61 | - |

- REMARKS:**
1. Q.P. and AV. are abbreviations of quasi-peak and average individually.
 2. "-": The Quasi-peak reading value also meets average limit and measurement with the average detector is unnecessary.
 3. The emission levels of other frequencies were very low against the limit.
 4. Margin value = Emission level - Limit value
 5. Correction factor = Insertion loss + Cable loss
 6. Emission Level = Correction Factor + Reading Value.

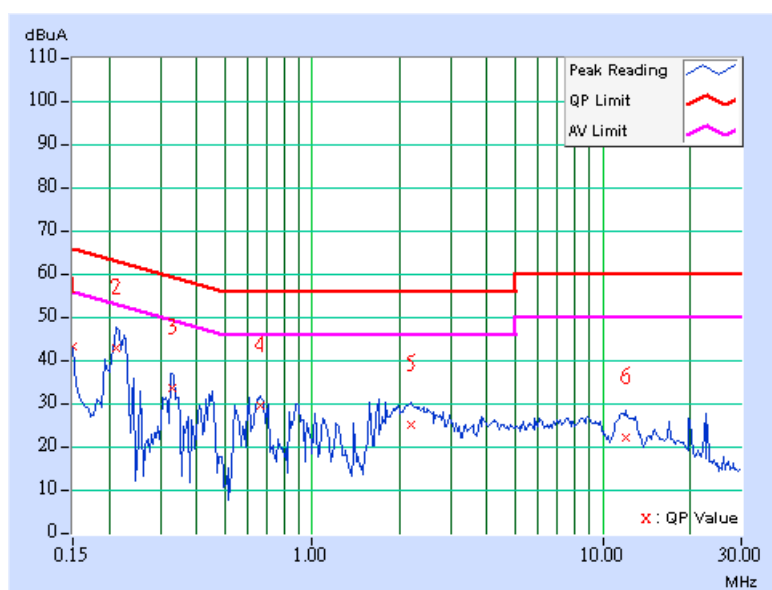

| EUT TEST CONDITION | | MEASUREMENT DETAIL | |
|--------------------------|-------------------------|----------------------|---------------|
| CHANNEL | Channel 39 | PHASE | Line 1 |
| MODULATION TYPE | GFSK | 6dB BANDWIDTH | 9 kHz |
| ENVIRONMENTAL CONDITIONS | 23deg. C, 68%RH, 991hPa | INPUT POWER (SYSTEM) | 120Vac, 60 Hz |
| TEST MODE | E | TESTED BY | Match Tsui |

| No | Freq. [MHz] | Corr. Factor [dB] | Reading Value [dB (uV)] | | Emission Level [dB (uV)] | | Limit [dB (uV)] | | Margin (dB) | |
|----|-------------|-------------------|-------------------------|-------|--------------------------|-------|-----------------|-------|-------------|-------|
| | | | Q.P. | AV. | Q.P. | AV. | Q.P. | AV. | Q.P. | AV. |
| | | | 1 | 0.150 | 0.10 | 46.04 | - | 46.14 | - | 66.00 |
| 2 | 0.220 | 0.10 | 44.37 | - | 44.47 | - | 62.81 | 52.81 | -18.34 | - |
| 3 | 0.326 | 0.10 | 33.52 | - | 33.62 | - | 59.56 | 49.56 | -25.94 | - |
| 4 | 0.955 | 0.10 | 25.22 | - | 25.32 | - | 56.00 | 46.00 | -30.68 | - |
| 5 | 2.113 | 0.21 | 25.44 | - | 25.65 | - | 56.00 | 46.00 | -30.35 | - |
| 6 | 9.262 | 0.36 | 21.98 | - | 22.34 | - | 60.00 | 50.00 | -37.66 | - |

- REMARKS:**
1. Q.P. and AV. are abbreviations of quasi-peak and average individually.
 2. "-": The Quasi-peak reading value also meets average limit and measurement with the average detector is unnecessary.
 3. The emission levels of other frequencies were very low against the limit.
 4. Margin value = Emission level - Limit value
 5. Correction factor = Insertion loss + Cable loss
 6. Emission Level = Correction Factor + Reading Value.

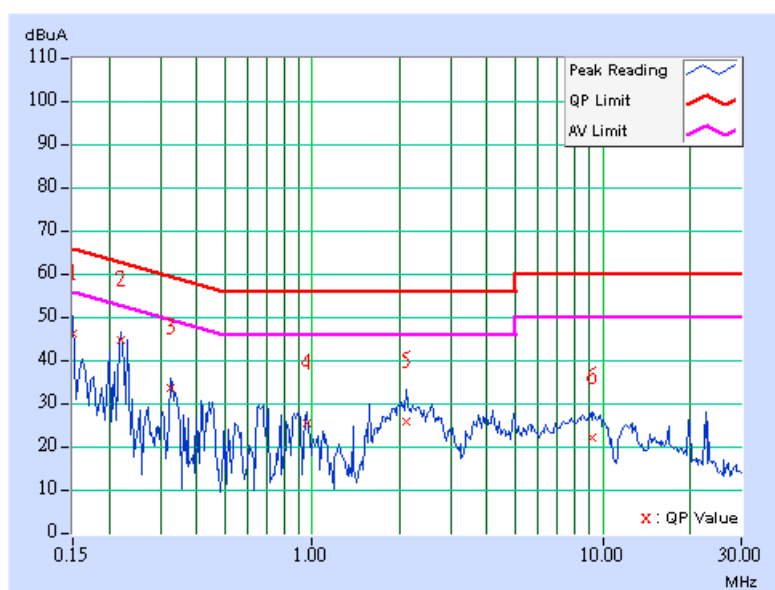

| EUT TEST CONDITION | | MEASUREMENT DETAIL | |
|--------------------------|-------------------------|----------------------|---------------|
| CHANNEL | Channel 39 | PHASE | Line 2 |
| MODULATION TYPE | GFSK | 6dB BANDWIDTH | 9 kHz |
| ENVIRONMENTAL CONDITIONS | 23deg. C, 68%RH, 991hPa | INPUT POWER (SYSTEM) | 120Vac, 60 Hz |
| TEST MODE | E | TESTED BY | Match Tsui |

| No | Freq. [MHz] | Corr. Factor [dB] | Reading Value [dB (uV)] | | Emission Level [dB (uV)] | | Limit [dB (uV)] | | Margin (dB) | |
|----|-------------|-------------------|-------------------------|-------|--------------------------|-------|-----------------|-------|-------------|-------|
| | | | Q.P. | AV. | Q.P. | AV. | Q.P. | AV. | Q.P. | AV. |
| | | | 1 | 0.150 | 0.10 | 43.08 | - | 43.18 | - | 66.00 |
| 2 | 0.216 | 0.10 | 45.10 | - | 45.20 | - | 62.96 | 52.96 | -17.76 | - |
| 3 | 0.333 | 0.10 | 32.88 | - | 32.98 | - | 59.38 | 49.38 | -26.40 | - |
| 4 | 0.455 | 0.11 | 30.05 | - | 30.16 | - | 56.79 | 46.79 | -26.63 | - |
| 5 | 1.871 | 0.20 | 25.26 | - | 25.46 | - | 56.00 | 46.00 | -30.54 | - |
| 6 | 12.484 | 0.54 | 21.18 | - | 21.72 | - | 60.00 | 50.00 | -38.28 | - |

- REMARKS:**
1. Q.P. and AV. are abbreviations of quasi-peak and average individually.
 2. "-": The Quasi-peak reading value also meets average limit and measurement with the average detector is unnecessary.
 3. The emission levels of other frequencies were very low against the limit.
 4. Margin value = Emission level - Limit value
 5. Correction factor = Insertion loss + Cable loss
 6. Emission Level = Correction Factor + Reading Value.

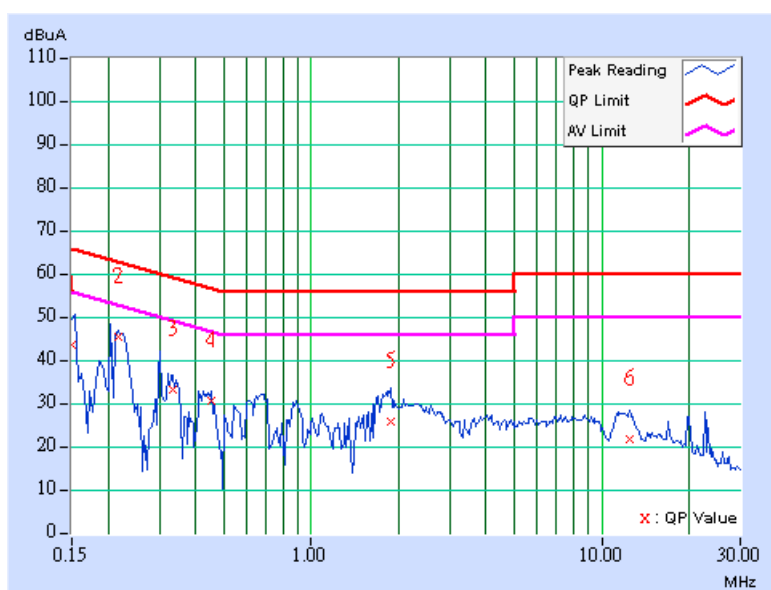

| EUT TEST CONDITION | | MEASUREMENT DETAIL | |
|--------------------------|-------------------------|----------------------|---------------|
| CHANNEL | Channel 78 | PHASE | Line 1 |
| MODULATION TYPE | GFSK | 6dB BANDWIDTH | 9 kHz |
| ENVIRONMENTAL CONDITIONS | 23deg. C, 68%RH, 991hPa | INPUT POWER (SYSTEM) | 120Vac, 60 Hz |
| TEST MODE | E | TESTED BY | Match Tsui |

| No | Freq. [MHz] | Corr. Factor [dB] | Reading Value [dB (uV)] | | Emission Level [dB (uV)] | | Limit [dB (uV)] | | Margin (dB) | |
|----|-------------|-------------------|-------------------------|-------|--------------------------|-------|-----------------|-------|-------------|-------|
| | | | Q.P. | AV. | Q.P. | AV. | Q.P. | AV. | Q.P. | AV. |
| | | | 1 | 0.158 | 0.10 | 40.72 | - | 40.82 | - | 65.58 |
| 2 | 0.224 | 0.10 | 41.79 | - | 41.89 | - | 62.66 | 52.66 | -20.77 | - |
| 3 | 0.334 | 0.10 | 24.43 | - | 24.53 | - | 59.36 | 49.36 | -34.83 | - |
| 4 | 0.705 | 0.10 | 27.34 | - | 27.44 | - | 56.00 | 46.00 | -28.56 | - |
| 5 | 1.891 | 0.19 | 25.25 | - | 25.44 | - | 56.00 | 46.00 | -30.56 | - |
| 6 | 9.340 | 0.36 | 21.76 | - | 22.12 | - | 60.00 | 50.00 | -37.88 | - |

- REMARKS:**
1. Q.P. and AV. are abbreviations of quasi-peak and average individually.
 2. "-": The Quasi-peak reading value also meets average limit and measurement with the average detector is unnecessary.
 3. The emission levels of other frequencies were very low against the limit.
 4. Margin value = Emission level - Limit value
 5. Correction factor = Insertion loss + Cable loss
 6. Emission Level = Correction Factor + Reading Value.

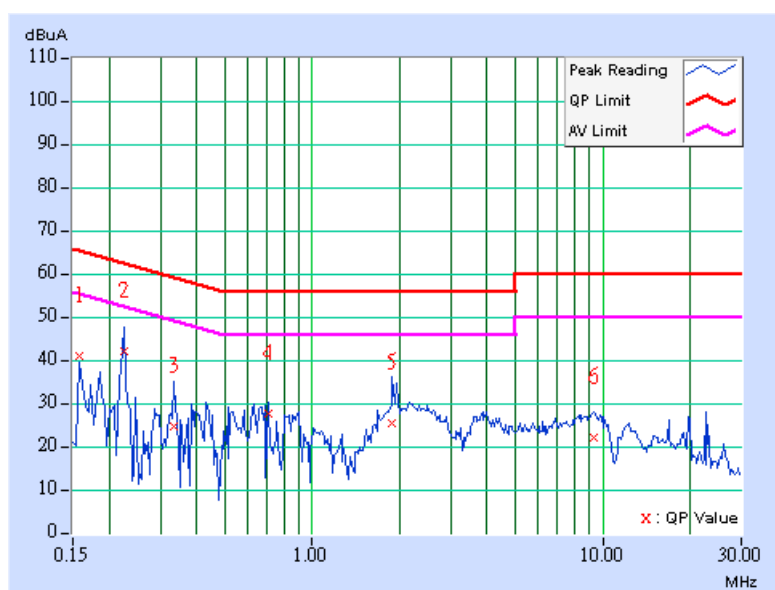

| EUT TEST CONDITION | | MEASUREMENT DETAIL | |
|--------------------------|-------------------------|----------------------|---------------|
| CHANNEL | Channel 78 | PHASE | Line 2 |
| MODULATION TYPE | GFSK | 6dB BANDWIDTH | 9 kHz |
| ENVIRONMENTAL CONDITIONS | 23deg. C, 68%RH, 991hPa | INPUT POWER (SYSTEM) | 120Vac, 60 Hz |
| TEST MODE | E | TESTED BY | Match Tsui |

| No | Freq. [MHz] | Corr. Factor (dB) | Reading Value [dB (uV)] | | Emission Level [dB (uV)] | | Limit [dB (uV)] | | Margin (dB) | |
|----|-------------|-------------------|-------------------------|-----|--------------------------|-----|-----------------|-------|-------------|-----|
| | | | Q.P. | AV. | Q.P. | AV. | Q.P. | AV. | Q.P. | AV. |
| 1 | 0.162 | 0.10 | 37.65 | - | 37.75 | - | 65.38 | 55.38 | -27.63 | - |
| 2 | 0.216 | 0.10 | 45.84 | - | 45.94 | - | 62.96 | 52.96 | -17.02 | - |
| 3 | 0.338 | 0.10 | 33.00 | - | 33.10 | - | 59.26 | 49.26 | -26.16 | - |
| 4 | 0.654 | 0.14 | 28.96 | - | 29.10 | - | 56.00 | 46.00 | -26.90 | - |
| 5 | 1.813 | 0.20 | 22.51 | - | 22.71 | - | 56.00 | 46.00 | -33.29 | - |
| 6 | 11.480 | 0.51 | 21.66 | - | 22.17 | - | 60.00 | 50.00 | -37.83 | - |

- REMARKS:**
1. Q.P. and AV. are abbreviations of quasi-peak and average individually.
 2. "-": The Quasi-peak reading value also meets average limit and measurement with the average detector is unnecessary.
 3. The emission levels of other frequencies were very low against the limit.
 4. Margin value = Emission level - Limit value
 5. Correction factor = Insertion loss + Cable loss
 6. Emission Level = Correction Factor + Reading Value.

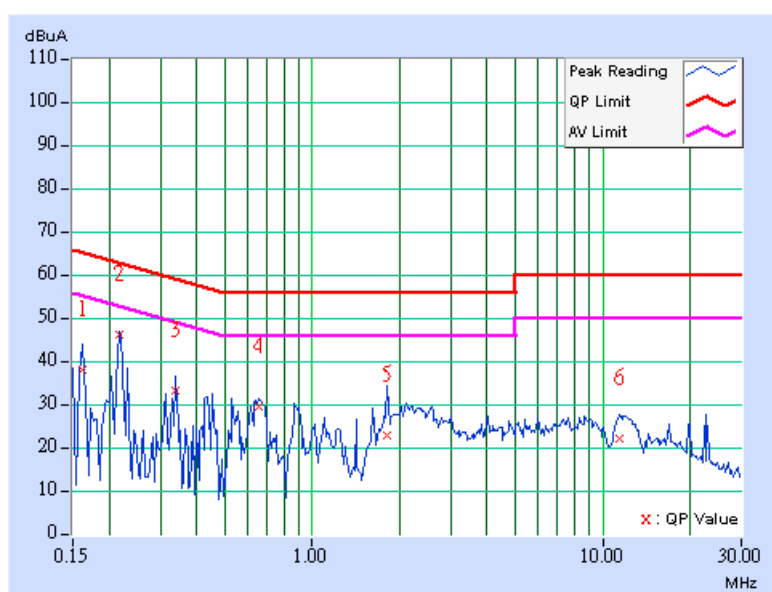

| EUT TEST CONDITION | | MEASUREMENT DETAIL | |
|--------------------------|-------------------------|----------------------|---------------|
| CHANNEL | Channel 0 | PHASE | Line 1 |
| MODULATION TYPE | GFSK | 6dB BANDWIDTH | 9 kHz |
| ENVIRONMENTAL CONDITIONS | 23deg. C, 68%RH, 991hPa | INPUT POWER (SYSTEM) | 120Vac, 60 Hz |
| TEST MODE | F | TESTED BY | Match Tsui |

| No | Freq. [MHz] | Corr. Factor (dB) | Reading Value [dB (uV)] | | Emission Level [dB (uV)] | | Limit [dB (uV)] | | Margin (dB) | |
|----|-------------|-------------------|-------------------------|-----|--------------------------|-----|-----------------|-------|-------------|-----|
| | | | Q.P. | AV. | Q.P. | AV. | Q.P. | AV. | Q.P. | AV. |
| 1 | 0.181 | 0.10 | 35.60 | - | 35.70 | - | 64.43 | 54.43 | -28.73 | - |
| 2 | 0.365 | 0.10 | 34.54 | - | 34.64 | - | 58.62 | 48.62 | -23.98 | - |
| 3 | 0.607 | 0.10 | 30.14 | - | 30.24 | - | 56.00 | 46.00 | -25.76 | - |
| 4 | 1.883 | 0.19 | 30.73 | - | 30.92 | - | 56.00 | 46.00 | -25.08 | - |
| 5 | 3.035 | 0.29 | 31.04 | - | 31.33 | - | 56.00 | 46.00 | -24.67 | - |
| 6 | 8.199 | 0.36 | 35.17 | - | 35.53 | - | 60.00 | 50.00 | -24.47 | - |

- REMARKS:**
1. Q.P. and AV. are abbreviations of quasi-peak and average individually.
 2. "-": The Quasi-peak reading value also meets average limit and measurement with the average detector is unnecessary.
 3. The emission levels of other frequencies were very low against the limit.
 4. Margin value = Emission level - Limit value
 5. Correction factor = Insertion loss + Cable loss
 6. Emission Level = Correction Factor + Reading Value.

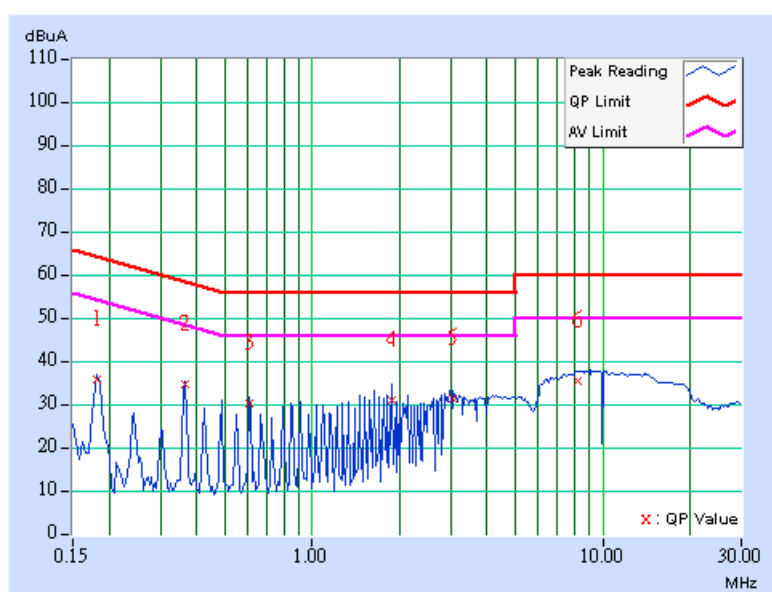

| EUT TEST CONDITION | | MEASUREMENT DETAIL | |
|--------------------------|-------------------------|----------------------|---------------|
| CHANNEL | Channel 0 | PHASE | Line 2 |
| MODULATION TYPE | GFSK | 6dB BANDWIDTH | 9 kHz |
| ENVIRONMENTAL CONDITIONS | 23deg. C, 68%RH, 991hPa | INPUT POWER (SYSTEM) | 120Vac, 60 Hz |
| TEST MODE | F | TESTED BY | Match Tsui |

| No | Freq. [MHz] | Corr. Factor [dB] | Reading Value [dB (uV)] | | Emission Level [dB (uV)] | | Limit [dB (uV)] | | Margin (dB) | |
|----|-------------|-------------------|-------------------------|-------|--------------------------|-------|-----------------|-------|-------------|-------|
| | | | Q.P. | AV. | Q.P. | AV. | Q.P. | AV. | Q.P. | AV. |
| | | | 1 | 0.181 | 0.10 | 34.90 | - | 35.00 | - | 64.43 |
| 2 | 0.365 | 0.10 | 35.03 | - | 35.13 | - | 58.62 | 48.62 | -23.49 | - |
| 3 | 0.486 | 0.11 | 30.66 | - | 30.77 | - | 56.24 | 46.24 | -25.46 | - |
| 4 | 1.336 | 0.20 | 28.61 | - | 28.81 | - | 56.00 | 46.00 | -27.19 | - |
| 5 | 2.914 | 0.28 | 31.87 | - | 32.15 | - | 56.00 | 46.00 | -23.85 | - |
| 6 | 9.051 | 0.45 | 35.22 | - | 35.67 | - | 60.00 | 50.00 | -24.33 | - |

- REMARKS:**
1. Q.P. and AV. are abbreviations of quasi-peak and average individually.
 2. "-": The Quasi-peak reading value also meets average limit and measurement with the average detector is unnecessary.
 3. The emission levels of other frequencies were very low against the limit.
 4. Margin value = Emission level - Limit value
 5. Correction factor = Insertion loss + Cable loss
 6. Emission Level = Correction Factor + Reading Value.

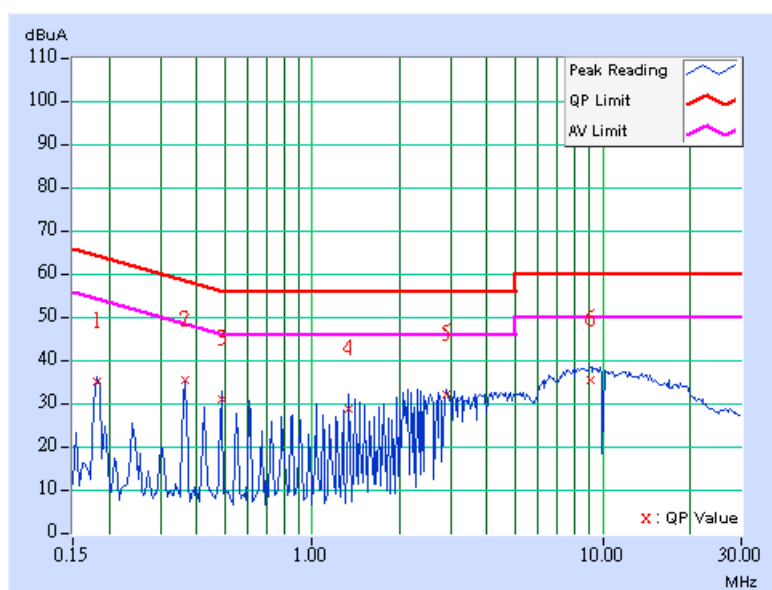

| EUT TEST CONDITION | | MEASUREMENT DETAIL | |
|--------------------------|-------------------------|----------------------|---------------|
| CHANNEL | Channel 39 | PHASE | Line 1 |
| MODULATION TYPE | GFSK | 6dB BANDWIDTH | 9 kHz |
| ENVIRONMENTAL CONDITIONS | 23deg. C, 68%RH, 991hPa | INPUT POWER (SYSTEM) | 120Vac, 60 Hz |
| TEST MODE | F | TESTED BY | Match Tsui |

| No | Freq. [MHz] | Corr. Factor [dB] | Reading Value [dB (uV)] | | Emission Level [dB (uV)] | | Limit [dB (uV)] | | Margin (dB) | |
|----|-------------|-------------------|-------------------------|-------|--------------------------|-------|-----------------|-------|-------------|-------|
| | | | Q.P. | AV. | Q.P. | AV. | Q.P. | AV. | Q.P. | AV. |
| | | | 1 | 0.181 | 0.10 | 35.67 | - | 35.77 | - | 64.43 |
| 2 | 0.365 | 0.10 | 34.54 | - | 34.64 | - | 58.62 | 48.62 | -23.98 | - |
| 3 | 0.607 | 0.10 | 30.14 | - | 30.24 | - | 56.00 | 46.00 | -25.76 | - |
| 4 | 1.887 | 0.19 | 28.17 | - | 28.36 | - | 56.00 | 46.00 | -27.64 | - |
| 5 | 4.191 | 0.37 | 30.14 | - | 30.51 | - | 56.00 | 46.00 | -25.49 | - |
| 6 | 13.668 | 0.56 | 34.01 | - | 34.57 | - | 60.00 | 50.00 | -25.43 | - |

- REMARKS:**
1. Q.P. and AV. are abbreviations of quasi-peak and average individually.
 2. "-": The Quasi-peak reading value also meets average limit and measurement with the average detector is unnecessary.
 3. The emission levels of other frequencies were very low against the limit.
 4. Margin value = Emission level - Limit value
 5. Correction factor = Insertion loss + Cable loss
 6. Emission Level = Correction Factor + Reading Value.

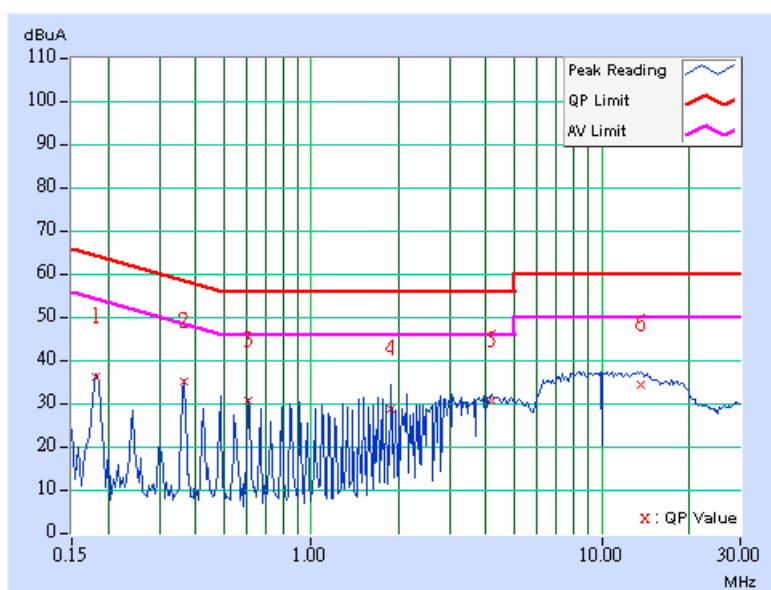

| EUT TEST CONDITION | | MEASUREMENT DETAIL | |
|--------------------------|-------------------------|----------------------|---------------|
| CHANNEL | Channel 39 | PHASE | Line 2 |
| MODULATION TYPE | GFSK | 6dB BANDWIDTH | 9 kHz |
| ENVIRONMENTAL CONDITIONS | 23deg. C, 68%RH, 991hPa | INPUT POWER (SYSTEM) | 120Vac, 60 Hz |
| TEST MODE | F | TESTED BY | Match Tsui |

| No | Freq. [MHz] | Corr. Factor [dB] | Reading Value [dB (uV)] | | Emission Level [dB (uV)] | | Limit [dB (uV)] | | Margin (dB) | |
|----|-------------|-------------------|-------------------------|-------|--------------------------|-------|-----------------|-------|-------------|-------|
| | | | Q.P. | AV. | Q.P. | AV. | Q.P. | AV. | Q.P. | AV. |
| | | | 1 | 0.184 | 0.10 | 34.60 | - | 34.70 | - | 64.30 |
| 2 | 0.365 | 0.10 | 35.09 | - | 35.19 | - | 58.62 | 48.62 | -23.43 | - |
| 3 | 0.791 | 0.17 | 29.62 | - | 29.79 | - | 56.00 | 46.00 | -26.21 | - |
| 4 | 1.941 | 0.20 | 31.00 | - | 31.20 | - | 56.00 | 46.00 | -24.80 | - |
| 5 | 2.672 | 0.26 | 33.84 | - | 34.10 | - | 56.00 | 46.00 | -21.90 | - |
| 6 | 8.262 | 0.43 | 35.56 | - | 35.99 | - | 60.00 | 50.00 | -24.01 | - |

- REMARKS:**
1. Q.P. and AV. are abbreviations of quasi-peak and average individually.
 2. "-": The Quasi-peak reading value also meets average limit and measurement with the average detector is unnecessary.
 3. The emission levels of other frequencies were very low against the limit.
 4. Margin value = Emission level - Limit value
 5. Correction factor = Insertion loss + Cable loss
 6. Emission Level = Correction Factor + Reading Value.

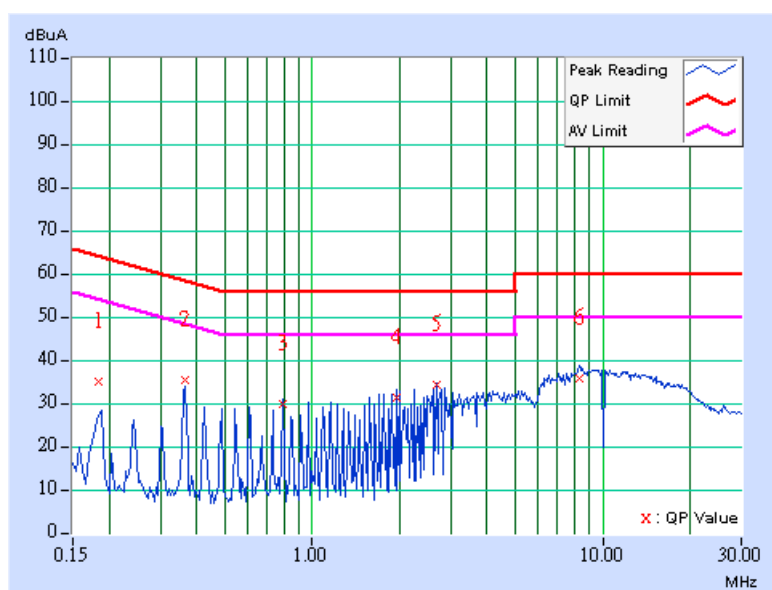

| EUT TEST CONDITION | | MEASUREMENT DETAIL | |
|--------------------------|-------------------------|----------------------|---------------|
| CHANNEL | Channel 78 | PHASE | Line 1 |
| MODULATION TYPE | GFSK | 6dB BANDWIDTH | 9 kHz |
| ENVIRONMENTAL CONDITIONS | 23deg. C, 68%RH, 991hPa | INPUT POWER (SYSTEM) | 120Vac, 60 Hz |
| TEST MODE | F | TESTED BY | Match Tsui |

| No | Freq. [MHz] | Corr. Factor [dB] | Reading Value [dB (uV)] | | Emission Level [dB (uV)] | | Limit [dB (uV)] | | Margin (dB) | |
|----|-------------|-------------------|-------------------------|-----|--------------------------|-----|-----------------|-------|-------------|-----|
| | | | Q.P. | AV. | Q.P. | AV. | Q.P. | AV. | Q.P. | AV. |
| | | | | | | | | | | |
| 1 | 0.181 | 0.10 | 35.73 | - | 35.83 | - | 64.43 | 54.43 | -28.60 | - |
| 2 | 0.365 | 0.10 | 34.54 | - | 34.64 | - | 58.62 | 48.62 | -23.98 | - |
| 3 | 0.607 | 0.10 | 30.10 | - | 30.20 | - | 56.00 | 46.00 | -25.80 | - |
| 4 | 1.457 | 0.15 | 30.42 | - | 30.57 | - | 56.00 | 46.00 | -25.43 | - |
| 5 | 2.793 | 0.27 | 30.30 | - | 30.57 | - | 56.00 | 46.00 | -25.43 | - |
| 6 | 8.625 | 0.36 | 34.86 | - | 35.22 | - | 60.00 | 50.00 | -24.78 | - |

- REMARKS:**
1. Q.P. and AV. are abbreviations of quasi-peak and average individually.
 2. "-": The Quasi-peak reading value also meets average limit and measurement with the average detector is unnecessary.
 3. The emission levels of other frequencies were very low against the limit.
 4. Margin value = Emission level - Limit value
 5. Correction factor = Insertion loss + Cable loss
 6. Emission Level = Correction Factor + Reading Value.

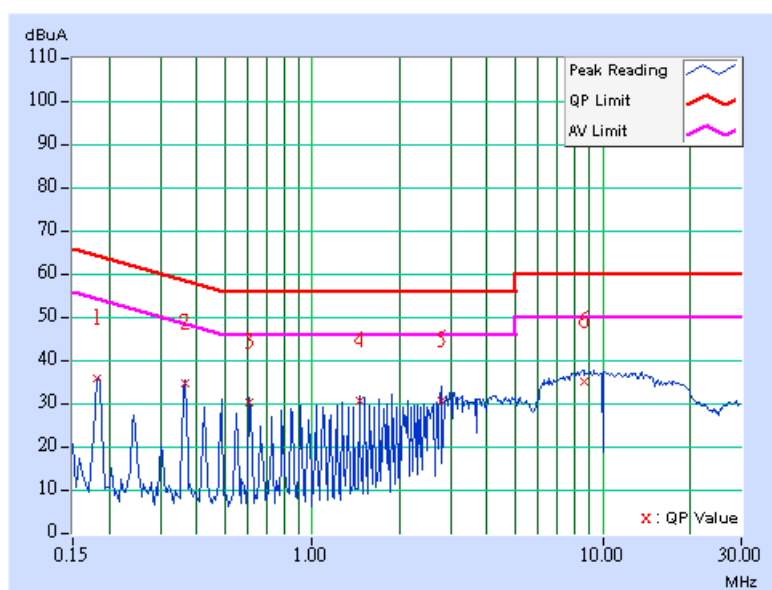

| EUT TEST CONDITION | | MEASUREMENT DETAIL | |
|--------------------------|-------------------------|----------------------|---------------|
| CHANNEL | Channel 78 | PHASE | Line 2 |
| MODULATION TYPE | GFSK | 6dB BANDWIDTH | 9 kHz |
| ENVIRONMENTAL CONDITIONS | 23deg. C, 68%RH, 991hPa | INPUT POWER (SYSTEM) | 120Vac, 60 Hz |
| TEST MODE | F | TESTED BY | Match Tsui |

| No | Freq. [MHz] | Corr. Factor [dB] | Reading Value [dB (uV)] | | Emission Level [dB (uV)] | | Limit [dB (uV)] | | Margin (dB) | |
|----|-------------|-------------------|-------------------------|-----|--------------------------|-----|-----------------|-------|-------------|-----|
| | | | Q.P. | AV. | Q.P. | AV. | Q.P. | AV. | Q.P. | AV. |
| | | | | | | | | | | |
| 1 | 0.181 | 0.10 | 35.26 | - | 35.36 | - | 64.43 | 54.43 | -29.07 | - |
| 2 | 0.365 | 0.10 | 35.05 | - | 35.15 | - | 58.62 | 48.62 | -23.47 | - |
| 3 | 0.791 | 0.17 | 29.60 | - | 29.77 | - | 56.00 | 46.00 | -26.23 | - |
| 4 | 2.613 | 0.25 | 32.76 | - | 33.01 | - | 56.00 | 46.00 | -22.99 | - |
| 5 | 5.223 | 0.39 | 30.63 | - | 31.02 | - | 60.00 | 50.00 | -28.98 | - |
| 6 | 9.355 | 0.45 | 35.78 | - | 36.23 | - | 60.00 | 50.00 | -23.77 | - |

- REMARKS:**
1. Q.P. and AV. are abbreviations of quasi-peak and average individually.
 2. "-": The Quasi-peak reading value also meets average limit and measurement with the average detector is unnecessary.
 3. The emission levels of other frequencies were very low against the limit.
 4. Margin value = Emission level - Limit value
 5. Correction factor = Insertion loss + Cable loss
 6. Emission Level = Correction Factor + Reading Value.

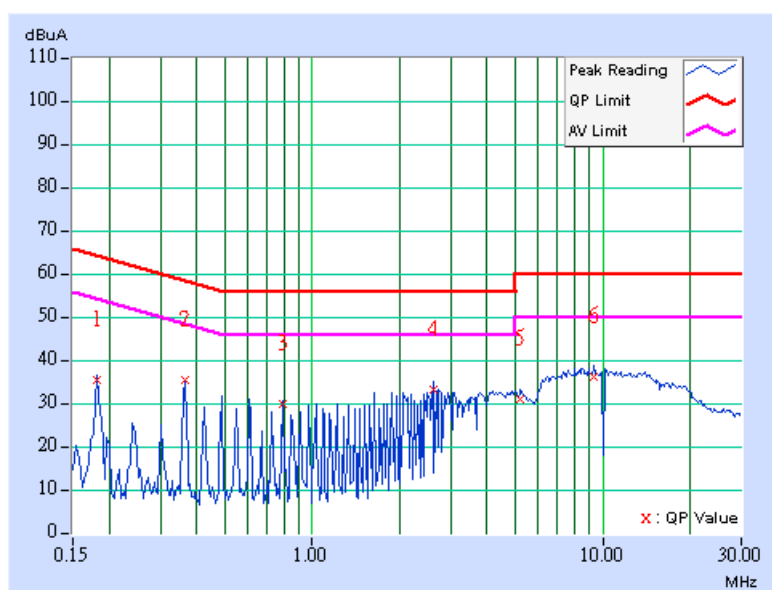

| EUT TEST CONDITION | | MEASUREMENT DETAIL | |
|--------------------------|-------------------------|----------------------|---------------|
| CHANNEL | Channel 0 | PHASE | Line 1 |
| MODULATION TYPE | GFSK | 6dB BANDWIDTH | 9 kHz |
| ENVIRONMENTAL CONDITIONS | 23deg. C, 68%RH, 991hPa | INPUT POWER (SYSTEM) | 120Vac, 60 Hz |
| TEST MODE | G | TESTED BY | Match Tsui |

| No | Freq. [MHz] | Corr. Factor (dB) | Reading Value [dB (uV)] | | Emission Level [dB (uV)] | | Limit [dB (uV)] | | Margin (dB) | |
|----|-------------|-------------------|-------------------------|-------|--------------------------|-------|-----------------|-------|-------------|-------|
| | | | Q.P. | AV. | Q.P. | AV. | Q.P. | AV. | Q.P. | AV. |
| 1 | 0.400 | 0.10 | 52.85 | 41.35 | 52.95 | 41.45 | 57.86 | 47.86 | -4.91 | -6.41 |
| 2 | 0.533 | 0.10 | 45.37 | - | 45.47 | - | 56.00 | 46.00 | -10.53 | - |
| 3 | 0.917 | 0.10 | 41.75 | - | 41.85 | - | 56.00 | 46.00 | -14.15 | - |
| 4 | 2.020 | 0.20 | 38.45 | - | 38.65 | - | 56.00 | 46.00 | -17.35 | - |
| 5 | 3.325 | 0.31 | 37.89 | - | 38.20 | - | 56.00 | 46.00 | -17.80 | - |
| 6 | 7.611 | 0.36 | 42.31 | - | 42.67 | - | 60.00 | 50.00 | -17.33 | - |

- REMARKS:**
1. Q.P. and AV. are abbreviations of quasi-peak and average individually.
 2. "-": The Quasi-peak reading value also meets average limit and measurement with the average detector is unnecessary.
 3. The emission levels of other frequencies were very low against the limit.
 4. Margin value = Emission level - Limit value
 5. Correction factor = Insertion loss + Cable loss
 6. Emission Level = Correction Factor + Reading Value.

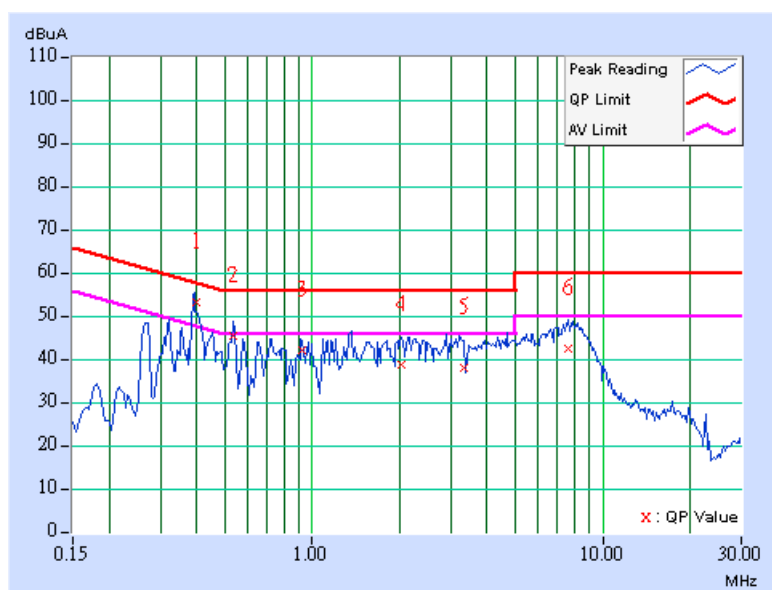

| EUT TEST CONDITION | | MEASUREMENT DETAIL | |
|--------------------------|-------------------------|----------------------|---------------|
| CHANNEL | Channel 0 | PHASE | Line 2 |
| MODULATION TYPE | GFSK | 6dB BANDWIDTH | 9 kHz |
| ENVIRONMENTAL CONDITIONS | 23deg. C, 68%RH, 991hPa | INPUT POWER (SYSTEM) | 120Vac, 60 Hz |
| TEST MODE | G | TESTED BY | Match Tsui |

| No | Freq. [MHz] | Corr. Factor [dB] | Reading Value [dB (uV)] | | Emission Level [dB (uV)] | | Limit [dB (uV)] | | Margin (dB) | |
|----|-------------|-------------------|-------------------------|-------|--------------------------|-------|-----------------|-------|-------------|-------|
| | | | Q.P. | AV. | Q.P. | AV. | Q.P. | AV. | Q.P. | AV. |
| | | | 1 | 0.412 | 0.10 | 50.32 | 39.59 | 50.42 | 39.69 | 57.60 |
| 2 | 0.916 | 0.19 | 39.20 | - | 39.39 | - | 56.00 | 46.00 | -16.61 | - |
| 3 | 1.233 | 0.20 | 37.74 | - | 37.94 | - | 56.00 | 46.00 | -18.06 | - |
| 4 | 2.652 | 0.26 | 34.20 | - | 34.46 | - | 56.00 | 46.00 | -21.54 | - |
| 5 | 3.754 | 0.35 | 35.58 | - | 35.93 | - | 56.00 | 46.00 | -20.07 | - |
| 6 | 8.225 | 0.43 | 40.74 | - | 41.17 | - | 60.00 | 50.00 | -18.83 | - |

- REMARKS:**
1. Q.P. and AV. are abbreviations of quasi-peak and average individually.
 2. "-": The Quasi-peak reading value also meets average limit and measurement with the average detector is unnecessary.
 3. The emission levels of other frequencies were very low against the limit.
 4. Margin value = Emission level - Limit value
 5. Correction factor = Insertion loss + Cable loss
 6. Emission Level = Correction Factor + Reading Value.

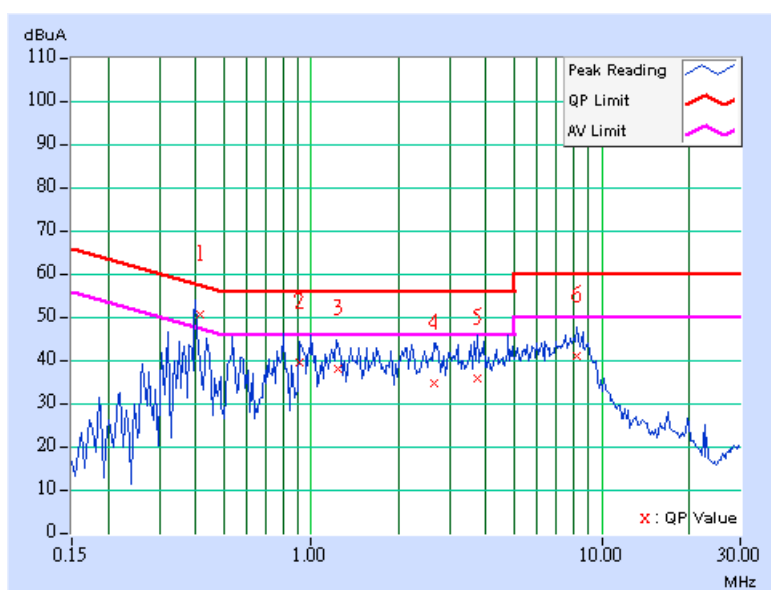

| EUT TEST CONDITION | | MEASUREMENT DETAIL | |
|--------------------------|-------------------------|----------------------|---------------|
| CHANNEL | Channel 39 | PHASE | Line 1 |
| MODULATION TYPE | GFSK | 6dB BANDWIDTH | 9 kHz |
| ENVIRONMENTAL CONDITIONS | 23deg. C, 68%RH, 991hPa | INPUT POWER (SYSTEM) | 120Vac, 60 Hz |
| TEST MODE | G | TESTED BY | Match Tsui |

| No | Freq. [MHz] | Corr. Factor [dB] | Reading Value [dB (uV)] | | Emission Level [dB (uV)] | | Limit [dB (uV)] | | Margin (dB) | |
|----|-------------|-------------------|-------------------------|-------|--------------------------|-------|-----------------|-------|-------------|-------|
| | | | Q.P. | AV. | Q.P. | AV. | Q.P. | AV. | Q.P. | AV. |
| | | | | | | | | | | |
| 1 | 0.400 | 0.10 | 52.58 | 42.67 | 52.68 | 42.77 | 57.85 | 47.85 | -5.17 | -5.08 |
| 2 | 0.537 | 0.10 | 45.51 | - | 45.61 | - | 56.00 | 46.00 | -10.39 | - |
| 3 | 0.936 | 0.10 | 41.23 | - | 41.33 | - | 56.00 | 46.00 | -14.67 | - |
| 4 | 2.219 | 0.22 | 38.81 | - | 39.03 | - | 56.00 | 46.00 | -16.97 | - |
| 5 | 4.137 | 0.37 | 39.62 | - | 39.99 | - | 56.00 | 46.00 | -16.01 | - |
| 6 | 8.164 | 0.36 | 42.05 | - | 42.41 | - | 60.00 | 50.00 | -17.59 | - |

- REMARKS:**
1. Q.P. and AV. are abbreviations of quasi-peak and average individually.
 2. "-": The Quasi-peak reading value also meets average limit and measurement with the average detector is unnecessary.
 3. The emission levels of other frequencies were very low against the limit.
 4. Margin value = Emission level - Limit value
 5. Correction factor = Insertion loss + Cable loss
 6. Emission Level = Correction Factor + Reading Value.

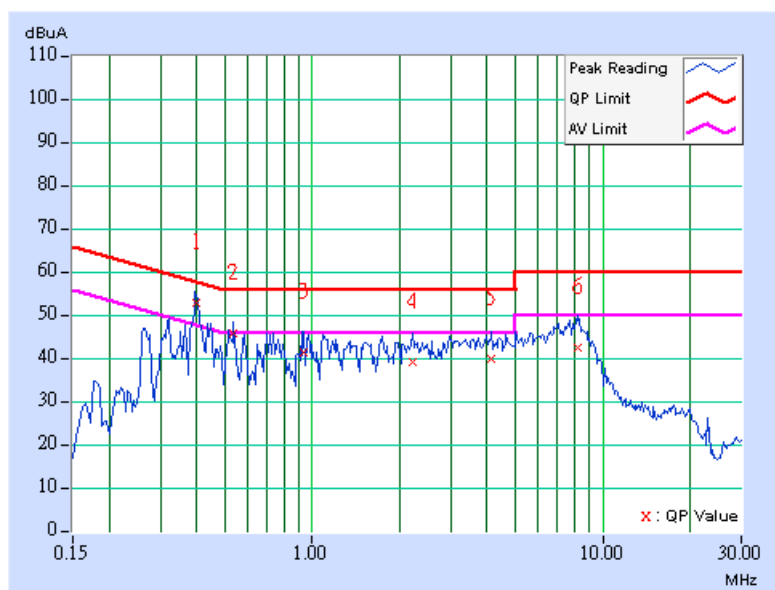

| EUT TEST CONDITION | | MEASUREMENT DETAIL | |
|--------------------------|-------------------------|----------------------|---------------|
| CHANNEL | Channel 39 | PHASE | Line 2 |
| MODULATION TYPE | GFSK | 6dB BANDWIDTH | 9 kHz |
| ENVIRONMENTAL CONDITIONS | 23deg. C, 68%RH, 991hPa | INPUT POWER (SYSTEM) | 120Vac, 60 Hz |
| TEST MODE | G | TESTED BY | Match Tsui |

| No | Freq. [MHz] | Corr. Factor [dB] | Reading Value [dB (uV)] | | Emission Level [dB (uV)] | | Limit [dB (uV)] | | Margin (dB) | |
|----|-------------|-------------------|-------------------------|-------|--------------------------|-------|-----------------|-------|-------------|-------|
| | | | Q.P. | AV. | Q.P. | AV. | Q.P. | AV. | Q.P. | AV. |
| | | | | | | | | | | |
| 1 | 0.322 | 0.10 | 42.47 | - | 42.57 | - | 59.64 | 49.64 | -17.07 | - |
| 2 | 0.412 | 0.10 | 49.44 | 38.95 | 49.54 | 39.05 | 57.60 | 47.60 | -8.06 | -8.55 |
| 3 | 0.542 | 0.12 | 40.89 | - | 41.01 | - | 56.00 | 46.00 | -14.99 | - |
| 4 | 1.936 | 0.20 | 35.36 | - | 35.56 | - | 56.00 | 46.00 | -20.44 | - |
| 5 | 3.725 | 0.35 | 35.96 | - | 36.31 | - | 56.00 | 46.00 | -19.69 | - |
| 6 | 8.254 | 0.43 | 42.22 | - | 42.65 | - | 60.00 | 50.00 | -17.35 | - |

- REMARKS:**
1. Q.P. and AV. are abbreviations of quasi-peak and average individually.
 2. "-": The Quasi-peak reading value also meets average limit and measurement with the average detector is unnecessary.
 3. The emission levels of other frequencies were very low against the limit.
 4. Margin value = Emission level - Limit value
 5. Correction factor = Insertion loss + Cable loss
 6. Emission Level = Correction Factor + Reading Value.

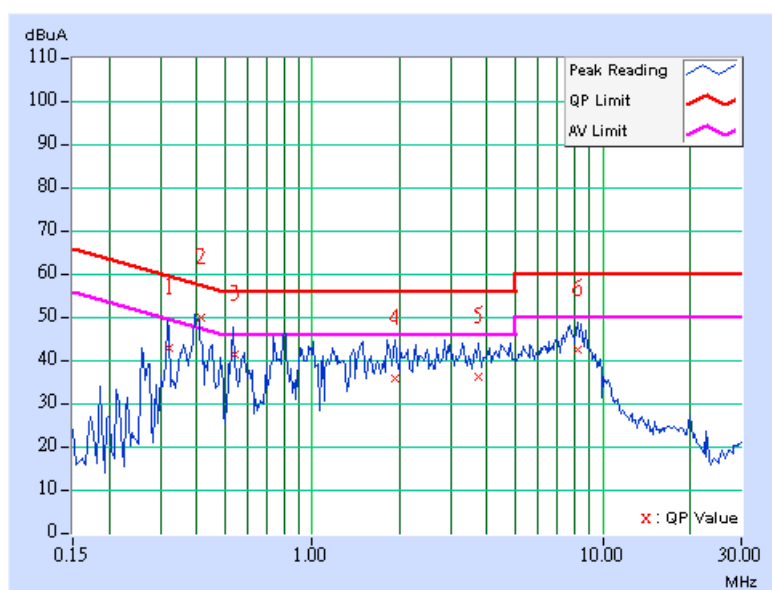

| EUT TEST CONDITION | | MEASUREMENT DETAIL | |
|--------------------------|-------------------------|----------------------|---------------|
| CHANNEL | Channel 78 | PHASE | Line 1 |
| MODULATION TYPE | GFSK | 6dB BANDWIDTH | 9 kHz |
| ENVIRONMENTAL CONDITIONS | 23deg. C, 68%RH, 991hPa | INPUT POWER (SYSTEM) | 120Vac, 60 Hz |
| TEST MODE | G | TESTED BY | Match Tsui |

| No | Freq. [MHz] | Corr. Factor [dB] | Reading Value [dB (uV)] | | Emission Level [dB (uV)] | | Limit [dB (uV)] | | Margin (dB) | |
|----|-------------|-------------------|-------------------------|-------|--------------------------|-------|-----------------|-------|-------------|-------|
| | | | Q.P. | AV. | Q.P. | AV. | Q.P. | AV. | Q.P. | AV. |
| 1 | 0.400 | 0.10 | 53.21 | 42.67 | 53.31 | 42.77 | 57.85 | 47.85 | -4.54 | -5.08 |
| 2 | 0.537 | 0.10 | 45.51 | - | 45.61 | - | 56.00 | 46.00 | -10.39 | - |
| 3 | 0.937 | 0.10 | 41.23 | - | 41.33 | - | 56.00 | 46.00 | -14.67 | - |
| 4 | 2.219 | 0.22 | 39.50 | - | 39.72 | - | 56.00 | 46.00 | -16.28 | - |
| 5 | 4.138 | 0.37 | 39.62 | - | 39.99 | - | 56.00 | 46.00 | -16.01 | - |
| 6 | 8.164 | 0.36 | 43.20 | - | 43.56 | - | 60.00 | 50.00 | -16.44 | - |

- REMARKS:**
1. Q.P. and AV. are abbreviations of quasi-peak and average individually.
 2. "-": The Quasi-peak reading value also meets average limit and measurement with the average detector is unnecessary.
 3. The emission levels of other frequencies were very low against the limit.
 4. Margin value = Emission level - Limit value
 5. Correction factor = Insertion loss + Cable loss
 6. Emission Level = Correction Factor + Reading Value.

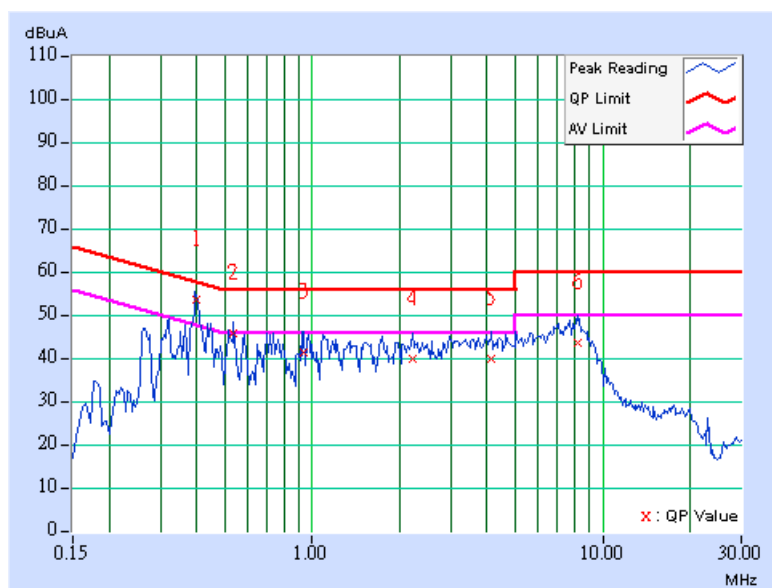

| EUT TEST CONDITION | | MEASUREMENT DETAIL | |
|--------------------------|-------------------------|----------------------|---------------|
| CHANNEL | Channel 78 | PHASE | Line 2 |
| MODULATION TYPE | GFSK | 6dB BANDWIDTH | 9 kHz |
| ENVIRONMENTAL CONDITIONS | 23deg. C, 68%RH, 991hPa | INPUT POWER (SYSTEM) | 120Vac, 60 Hz |
| TEST MODE | G | TESTED BY | Match Tsui |

| No | Freq. [MHz] | Corr. Factor (dB) | Reading Value [dB (uV)] | | Emission Level [dB (uV)] | | Limit [dB (uV)] | | Margin (dB) | |
|----|-------------|-------------------|-------------------------|-------|--------------------------|-------|-----------------|-------|-------------|-------|
| | | | Q.P. | AV. | Q.P. | AV. | Q.P. | AV. | Q.P. | AV. |
| 1 | 0.400 | 0.10 | 49.85 | 41.20 | 49.95 | 41.30 | 57.85 | 47.85 | -7.90 | -6.55 |
| 2 | 0.565 | 0.13 | 38.32 | - | 38.45 | - | 56.00 | 46.00 | -17.55 | - |
| 3 | 0.835 | 0.17 | 38.96 | - | 39.13 | - | 56.00 | 46.00 | -16.87 | - |
| 4 | 1.175 | 0.20 | 39.21 | - | 39.41 | - | 56.00 | 46.00 | -16.59 | - |
| 5 | 3.051 | 0.29 | 36.54 | - | 36.83 | - | 56.00 | 46.00 | -19.17 | - |
| 6 | 7.954 | 0.43 | 40.50 | - | 40.93 | - | 60.00 | 50.00 | -19.07 | - |

- REMARKS:**
1. Q.P. and AV. are abbreviations of quasi-peak and average individually.
 2. "-": The Quasi-peak reading value also meets average limit and measurement with the average detector is unnecessary.
 3. The emission levels of other frequencies were very low against the limit.
 4. Margin value = Emission level - Limit value
 5. Correction factor = Insertion loss + Cable loss
 6. Emission Level = Correction Factor + Reading Value.

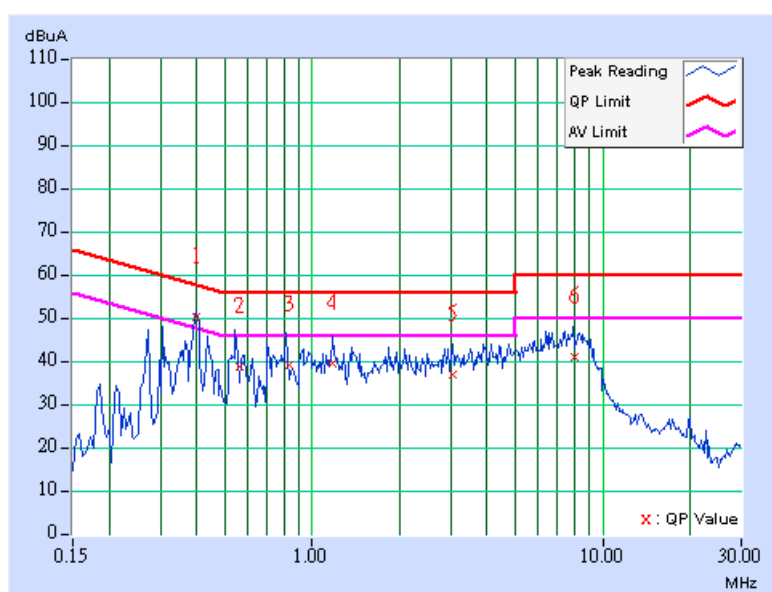



4.2 RADIATED EMISSION MEASUREMENT

4.2.1 LIMITS OF RADIATED EMISSION MEASUREMENT

Emissions radiated outside of the specified bands, shall be according to the general radiated limits in 15.209 as following:

| FREQUENCIES (MHz) | FIELD STRENGTH (microvolts/meter) | MEASUREMENT DISTANCE (meters) |
|-------------------|-----------------------------------|-------------------------------|
| 0.009-0.490 | 2400/F(kHz) | 300 |
| 0.490-1.705 | 24000/F(kHz) | 30 |
| 1.705-30.0 | 30 | 30 |
| 30-88 | 100 | 3 |
| 88-216 | 150 | 3 |
| 216-960 | 200 | 3 |
| Above 960 | 500 | 3 |

NOTE:

1. The lower limit shall apply at the transition frequencies.
2. Emission level (dBuV/m) = 20 log Emission level (uV/m).
3. As shown in 15.35(b), for frequencies above 1000MHz, the field strength limits are based on average detector, however, the peak field strength of any emission shall not exceed the maximum permitted average limits, specified above by more than 20dB under any condition of modulation.

4.2.2 TEST INSTRUMENTS

| DESCRIPTION & MANUFACTURER | MODEL NO. | SERIAL NO. | CALIBRATED UNTIL |
|--------------------------------------|--------------------------|--------------------------|------------------|
| Test Receiver ROHDE & SCHWARZ | ESMI | 839013/007 839379/002 | Jan. 24, 2007 |
| Spectrum Analyzer ROHDE & SCHWARZ | FSEK30 | 100049 | Aug. 13, 2007 |
| BILOG Antenna SCHWARZBECK | VULB9163 | 121 | Jun. 01, 2007 |
| HORN Antenna SCHWARZBECK | BBHA 9120 D | 9120D-407 | Jan. 22, 2007 |
| HORN Antenna SCHWARZBECK | BBHA 9170 | BBHA9170242 | Jan. 19, 2007 |
| Preamplifier Agilent | 8449B | 3008A01911 | Sep. 21, 2007 |
| RF signal cable HUBER+SUHNNER | SUCOFLEX 104 | 218188/218189 | Dec. 13, 2006 |
| RF signal cable Worken | 8D-FB | Cable-HYCH9-01 | Mar. 08, 2007 |
| Software ADT. | ADT_Radiated_ V7.6.01 | NA | NA |
| Antenna Tower EMCO | 2070/2080 | 512.835.4684 | NA |
| Antenna Tower Controller EMCO | 2090 | NA | NA |
| Turn Table EMCO | 2087-2.03 | NA | NA |
| Turn Table Controller EMCO | 2090 | NA | NA |

- NOTE:**
1. The calibration interval of the above test instruments is 12 months and the calibrations are traceable to NML/ROC and NIST/USA.
 2. The test was performed in HwaYa Chamber 9.
 3. The horn antenna and HP preamplifier (model: 8449B) are used only for the measurement of emission frequency above 1GHz if tested.
 4. The IC Site Registration No. is IC4924A-9.

4.2.3 TEST PROCEDURES

- a. The EUT was placed on the top of a rotating table 0.8 meters above the ground at a 3 meter semi-anechoic chamber. The table was rotated 360 degrees to determine the position of the highest radiation.
- b. The EUT was set 3 meters away from the interference-receiving antenna, which was mounted on the top of a variable-height antenna tower.
- c. The antenna is a broadband antenna, and its height is varied from one meter to four meters above the ground to determine the maximum value of the field strength. Both horizontal and vertical polarizations of the antenna are set to make the measurement.
- d. For each suspected emission, the EUT was arranged to its worst case and then the antenna was tuned to heights from 1 meter to 4 meters and the rotatable table was turned from 0 degrees to 360 degrees to find the maximum reading.
- e. The test-receiver system was set to Peak Detect Function and Specified Bandwidth with Maximum Hold Mode.
- f. If the emission level of the EUT in peak mode was lower than the limit specified, then testing could be stopped and the peak values of the EUT would be reported. Otherwise the emissions would be re-tested one by one using peak, quasi-peak or average method as specified and then reported in a data sheet.

NOTE:

1. The resolution bandwidth and video bandwidth of test receiver/spectrum analyzer is 120kHz for Quasi-peak detection at frequency below 1GHz.
2. The resolution bandwidth of test receiver/spectrum analyzer is 1 MHz and video bandwidth is 3MHz for Peak detection at frequency above 1GHz.

4.2.4 DEVIATION FROM TEST STANDARD

No deviation

4.2.5 TEST SETUP

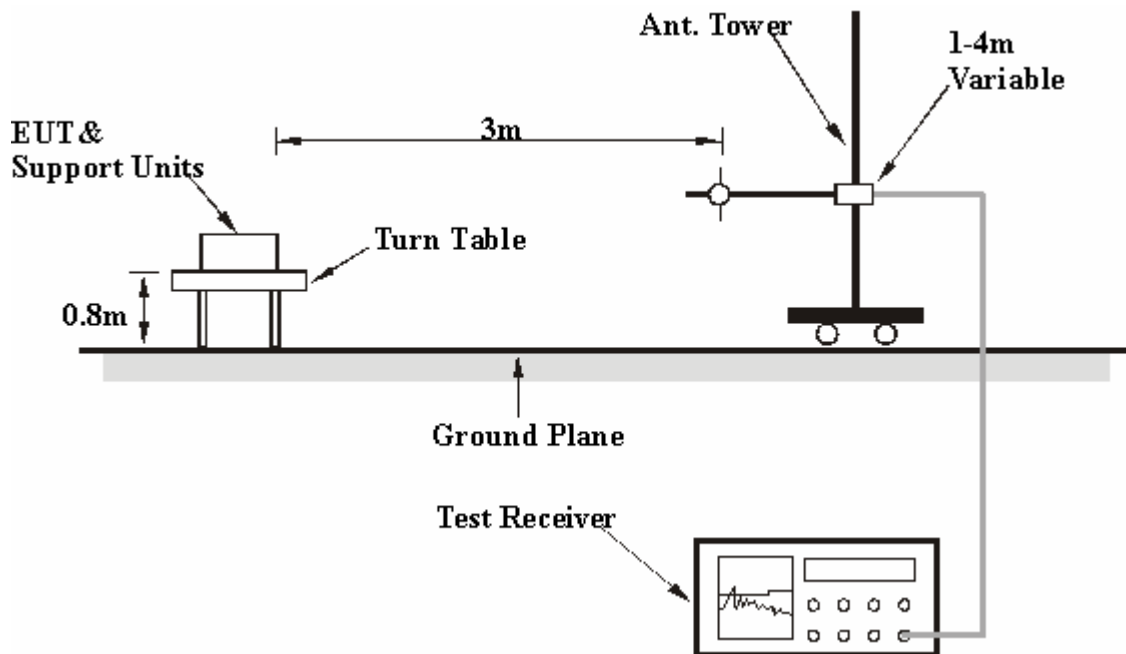

For the actual test configuration, please refer to the attached file (Test Setup Photo).

4.2.6 EUT OPERATING CONDITIONS

Same as 4.1.6

4.2.7 TEST RESULTS

RADIATED WORST CASE DATA:

| EUT TEST CONDITION | | MEASUREMENT DETAIL | |
|--------------------------|-------------------------|----------------------|---------------|
| CHANNEL | Channel 78 | FREQUENCY RANGE | Below 1000MHz |
| MODULATION TYPE | GFSK | DETECTOR FUNCTION | Quasi-Peak |
| ENVIRONMENTAL CONDITIONS | 26deg. C, 65%RH, 991hPa | INPUT POWER (SYSTEM) | 120Vac, 60 Hz |
| TEST MODE | A | TESTED BY | Match Tsui |

| ANTENNA POLARITY & TEST DISTANCE: HORIZONTAL AT 3 M | | | | | | | | |
|---|-------------|-------------------------|----------------|-------------|--------------------|----------------------|------------------|--------------------------|
| No. | Freq. (MHz) | Emission Level (dBuV/m) | Limit (dBuV/m) | Margin (dB) | Antenna Height (m) | Table Angle (Degree) | Raw Value (dBuV) | Correction Factor (dB/m) |
| 1 | 30.00 | 22.96 QP | 40.00 | -17.04 | 1.50 H | 282 | 11.29 | 11.67 |
| 2 | 127.19 | 29.97 QP | 43.50 | -13.53 | 2.00 H | 29 | 18.98 | 10.99 |
| 3 | 133.03 | 27.17 QP | 43.50 | -16.33 | 1.00 H | 244 | 15.41 | 11.76 |
| 4 | 191.34 | 23.57 QP | 43.50 | -19.93 | 2.00 H | 200 | 13.07 | 10.50 |
| 5 | 210.78 | 31.23 QP | 43.50 | -12.27 | 2.00 H | 24 | 20.94 | 10.28 |
| 6 | 255.49 | 29.21 QP | 46.00 | -16.79 | 1.00 H | 29 | 17.67 | 11.54 |
| 7 | 269.10 | 27.33 QP | 46.00 | -18.67 | 2.00 H | 30 | 14.25 | 13.08 |
| 8 | 640.38 | 29.75 QP | 46.00 | -16.25 | 2.00 H | 24 | 8.50 | 21.25 |
| 9 | 930.02 | 26.21 QP | 46.00 | -19.79 | 2.00 H | 23 | -0.18 | 26.39 |
| 10 | 949.46 | 30.77 QP | 46.00 | -15.23 | 1.00 H | 86 | 3.44 | 27.33 |

| ANTENNA POLARITY & TEST DISTANCE: VERTICAL AT 3 M | | | | | | | | |
|---|-------------|-------------------------|----------------|-------------|--------------------|----------------------|------------------|--------------------------|
| No. | Freq. (MHz) | Emission Level (dBuV/m) | Limit (dBuV/m) | Margin (dB) | Antenna Height (m) | Table Angle (Degree) | Raw Value (dBuV) | Correction Factor (dB/m) |
| 1 | 57.21 | 30.36 QP | 40.00 | -9.64 | 1.00 V | 263 | 17.09 | 13.27 |
| 2 | 127.19 | 28.34 QP | 43.50 | -15.16 | 1.00 V | 187 | 17.35 | 10.99 |
| 3 | 136.91 | 27.79 QP | 43.50 | -15.71 | 1.00 V | 30 | 15.51 | 12.28 |
| 4 | 162.18 | 26.66 QP | 43.50 | -16.84 | 1.00 V | 67 | 14.21 | 12.45 |
| 5 | 210.78 | 26.95 QP | 43.50 | -16.55 | 1.50 V | 289 | 16.66 | 10.28 |
| 6 | 241.88 | 29.84 QP | 46.00 | -16.16 | 1.00 V | 23 | 18.53 | 11.31 |
| 7 | 640.38 | 28.70 QP | 46.00 | -17.30 | 1.50 V | 289 | 7.45 | 21.25 |
| 8 | 945.57 | 33.93 QP | 46.00 | -12.07 | 1.00 V | 118 | 6.78 | 27.14 |

- REMARKS:**
1. Emission level (dBuV/m) = Raw Value (dBuV) + Correction Factor (dB/m).
 2. Correction Factor (dB/m) = Antenna Factor (dB/m) + Cable Factor (dB).
 3. The other emission levels were very low against the limit.
 4. Margin value = Emission level – Limit value.

| EUT TEST CONDITION | | MEASUREMENT DETAIL | |
|--------------------------|-------------------------|----------------------|---------------|
| CHANNEL | Channel 78 | FREQUENCY RANGE | Below 1000MHz |
| MODULATION TYPE | GFSK | DETECTOR FUNCTION | Quasi-Peak |
| ENVIRONMENTAL CONDITIONS | 26deg. C, 65%RH, 991hPa | INPUT POWER (SYSTEM) | 120Vac, 60 Hz |
| TEST MODE | B | TESTED BY | Match Tsui |

| ANTENNA POLARITY & TEST DISTANCE: HORIZONTAL AT 3 M | | | | | | | | |
|---|-------------|-------------------------|----------------|-------------|--------------------|----------------------|------------------|--------------------------|
| No. | Freq. (MHz) | Emission Level (dBuV/m) | Limit (dBuV/m) | Margin (dB) | Antenna Height (m) | Table Angle (Degree) | Raw Value (dBuV) | Correction Factor (dB/m) |
| 1 | 49.44 | 21.77 QP | 40.00 | -18.23 | 2.00 H | 80 | 7.89 | 13.88 |
| 2 | 121.36 | 28.77 QP | 43.50 | -14.73 | 2.00 H | 86 | 18.56 | 10.22 |
| 3 | 133.03 | 24.03 QP | 43.50 | -19.47 | 2.00 H | 263 | 12.27 | 11.76 |
| 4 | 210.78 | 23.50 QP | 43.50 | -20.00 | 2.00 H | 92 | 13.22 | 10.28 |
| 5 | 230.22 | 27.10 QP | 46.00 | -18.90 | 2.00 H | 289 | 16.18 | 10.92 |
| 6 | 640.38 | 25.48 QP | 46.00 | -20.52 | 2.00 H | 92 | 4.24 | 21.25 |
| 7 | 768.68 | 27.76 QP | 46.00 | -18.24 | 2.00 H | 92 | 3.82 | 23.94 |
| 8 | 933.91 | 26.46 QP | 46.00 | -19.54 | 2.00 H | 86 | -0.12 | 26.58 |
| 9 | 951.40 | 31.76 QP | 46.00 | -14.24 | 1.50 H | 54 | 4.44 | 27.32 |

| ANTENNA POLARITY & TEST DISTANCE: VERTICAL AT 3 M | | | | | | | | |
|---|--------------|-------------------------|----------------|--------------|--------------------|----------------------|------------------|--------------------------|
| No. | Freq. (MHz) | Emission Level (dBuV/m) | Limit (dBuV/m) | Margin (dB) | Antenna Height (m) | Table Angle (Degree) | Raw Value (dBuV) | Correction Factor (dB/m) |
| 1 | 51.38 | 36.59 QP | 40.00 | -3.41 | 1.00 V | 358 | 22.89 | 13.70 |
| 2 | 63.05 | 24.51 QP | 40.00 | -15.49 | 1.00 V | 61 | 11.92 | 12.60 |
| 3 | 113.59 | 24.95 QP | 43.50 | -18.55 | 1.00 V | 17 | 15.45 | 9.50 |
| 4 | 136.91 | 27.72 QP | 43.50 | -15.78 | 1.00 V | 67 | 15.44 | 12.28 |
| 5 | 162.18 | 29.15 QP | 43.50 | -14.35 | 1.00 V | 61 | 16.70 | 12.45 |
| 6 | 210.78 | 25.71 QP | 43.50 | -17.79 | 1.00 V | 48 | 15.43 | 10.28 |
| 7 | 241.88 | 29.96 QP | 46.00 | -16.04 | 1.00 V | 308 | 18.66 | 11.31 |
| 8 | 383.79 | 27.25 QP | 46.00 | -18.75 | 1.00 V | 358 | 11.10 | 16.15 |
| 9 | 512.08 | 26.02 QP | 46.00 | -19.98 | 1.00 V | 327 | 7.17 | 18.85 |
| 10 | 640.38 | 28.01 QP | 46.00 | -17.99 | 1.00 V | 48 | 6.77 | 21.25 |
| 11 | 935.85 | 26.02 QP | 46.00 | -19.98 | 1.00 V | 339 | -0.65 | 26.67 |
| 12 | 945.57 | 34.59 QP | 46.00 | -11.41 | 1.00 V | 327 | 7.44 | 27.14 |

- REMARKS:**
1. Emission level(dBuV/m)=Raw Value(dBuV) + Correction Factor(dB/m)
 2. Correction Factor(dB/m) = Antenna Factor (dB/m) + Cable Factor (dB)
 3. The other emission levels were very low against the limit.
 4. Margin value = Emission level – Limit value.



| EUT TEST CONDITION | | MEASUREMENT DETAIL | |
|--------------------------|-------------------------|----------------------|---------------|
| CHANNEL | Channel 78 | FREQUENCY RANGE | Below 1000MHz |
| MODULATION TYPE | GFSK | DETECTOR FUNCTION | Quasi-Peak |
| ENVIRONMENTAL CONDITIONS | 26deg. C, 65%RH, 991hPa | INPUT POWER (SYSTEM) | 120Vac, 60 Hz |
| TEST MODE | C | TESTED BY | Match Tsui |

| ANTENNA POLARITY & TEST DISTANCE: HORIZONTAL AT 3 M | | | | | | | | |
|---|-------------|-------------------------|----------------|-------------|--------------------|----------------------|------------------|--------------------------|
| No. | Freq. (MHz) | Emission Level (dBuV/m) | Limit (dBuV/m) | Margin (dB) | Antenna Height (m) | Table Angle (Degree) | Raw Value (dBuV) | Correction Factor (dB/m) |
| 1 | 76.65 | 25.06 QP | 40.00 | -14.94 | 2.00 H | 23 | 14.52 | 10.54 |
| 2 | 119.42 | 29.51 QP | 43.50 | -13.99 | 2.00 H | 5 | 19.52 | 9.99 |
| 3 | 142.75 | 32.14 QP | 43.50 | -11.36 | 2.00 H | 23 | 19.47 | 12.67 |
| 4 | 191.34 | 31.99 QP | 43.50 | -11.51 | 2.00 H | 80 | 21.48 | 10.50 |
| 5 | 210.78 | 30.48 QP | 43.50 | -13.02 | 2.50 H | 111 | 20.20 | 10.28 |
| 6 | 383.79 | 34.36 QP | 46.00 | -11.64 | 2.00 H | 5 | 18.22 | 16.15 |
| 7 | 521.80 | 30.96 QP | 46.00 | -15.04 | 2.00 H | 80 | 11.92 | 19.04 |
| 8 | 601.50 | 29.25 QP | 46.00 | -16.75 | 2.00 H | 219 | 8.43 | 20.82 |
| 9 | 720.08 | 30.64 QP | 46.00 | -15.36 | 2.00 H | 80 | 7.63 | 23.00 |
| 10 | 760.90 | 30.29 QP | 46.00 | -15.71 | 2.00 H | 187 | 6.37 | 23.93 |
| 11 | 799.78 | 28.42 QP | 46.00 | -17.58 | 2.50 H | 111 | 4.44 | 23.98 |
| 12 | 945.57 | 32.93 QP | 46.00 | -13.07 | 2.00 H | 130 | 5.78 | 27.14 |

| ANTENNA POLARITY & TEST DISTANCE: VERTICAL AT 3 M | | | | | | | | |
|---|-------------|-------------------------|----------------|-------------|--------------------|----------------------|------------------|--------------------------|
| No. | Freq. (MHz) | Emission Level (dBuV/m) | Limit (dBuV/m) | Margin (dB) | Antenna Height (m) | Table Angle (Degree) | Raw Value (dBuV) | Correction Factor (dB/m) |
| 1 | 41.66 | 29.47 QP | 40.00 | -10.53 | 1.00 V | 111 | 15.35 | 14.11 |
| 2 | 76.65 | 25.65 QP | 40.00 | -14.35 | 1.00 V | 175 | 15.12 | 10.54 |
| 3 | 113.59 | 29.88 QP | 43.50 | -13.62 | 1.00 V | 200 | 20.38 | 9.50 |
| 4 | 142.75 | 29.95 QP | 43.50 | -13.55 | 1.00 V | 175 | 17.28 | 12.67 |
| 5 | 191.34 | 28.09 QP | 43.50 | -15.41 | 1.50 V | 295 | 17.59 | 10.50 |
| 6 | 465.43 | 28.06 QP | 46.00 | -17.94 | 1.00 V | 73 | 10.21 | 17.85 |
| 7 | 601.50 | 31.53 QP | 46.00 | -14.47 | 1.00 V | 99 | 10.71 | 20.82 |
| 8 | 640.38 | 29.95 QP | 46.00 | -16.05 | 1.00 V | 124 | 8.70 | 21.25 |
| 9 | 681.20 | 29.70 QP | 46.00 | -16.30 | 1.50 V | 175 | 7.70 | 22.00 |
| 10 | 720.08 | 32.48 QP | 46.00 | -13.52 | 1.50 V | 295 | 9.48 | 23.00 |
| 11 | 731.74 | 32.26 QP | 46.00 | -13.74 | 1.00 V | 99 | 8.90 | 23.36 |
| 12 | 760.90 | 30.68 QP | 46.00 | -15.32 | 1.00 V | 99 | 6.76 | 23.93 |
| 13 | 801.72 | 30.35 QP | 46.00 | -15.65 | 1.00 V | 200 | 6.34 | 24.01 |
| 14 | 863.93 | 30.59 QP | 46.00 | -15.41 | 1.00 V | 200 | 5.90 | 24.69 |
| 15 | 945.57 | 36.55 QP | 46.00 | -9.45 | 1.00 V | 73 | 9.41 | 27.14 |

REMARKS:

1. Emission level(dBuV/m)=Raw Value(dBuV) + Correction Factor(dB/m)
2. Correction Factor(dB/m) = Antenna Factor (dB/m) + Cable Factor (dB)
3. The other emission levels were very low against the limit.
4. Margin value = Emission level – Limit value.



| EUT TEST CONDITION | | MEASUREMENT DETAIL | |
|--------------------------|-------------------------|----------------------|---------------|
| CHANNEL | Channel 78 | FREQUENCY RANGE | Below 1000MHz |
| MODULATION TYPE | GFSK | DETECTOR FUNCTION | Quasi-Peak |
| ENVIRONMENTAL CONDITIONS | 26deg. C, 65%RH, 991hPa | INPUT POWER (SYSTEM) | 120Vac, 60 Hz |
| TEST MODE | D | TESTED BY | Match Tsui |

| ANTENNA POLARITY & TEST DISTANCE: HORIZONTAL AT 3 M | | | | | | | | |
|---|-------------|-------------------------|----------------|-------------|--------------------|----------------------|------------------|--------------------------|
| No. | Freq. (MHz) | Emission Level (dBuV/m) | Limit (dBuV/m) | Margin (dB) | Antenna Height (m) | Table Angle (Degree) | Raw Value (dBuV) | Correction Factor (dB/m) |
| 1 | 72.77 | 26.62 QP | 40.00 | -13.38 | 2.00 H | 213 | 15.52 | 11.10 |
| 2 | 142.75 | 32.21 QP | 43.50 | -11.29 | 2.50 H | 10 | 19.53 | 12.67 |
| 3 | 210.78 | 30.92 QP | 43.50 | -12.58 | 2.00 H | 213 | 20.63 | 10.28 |
| 4 | 517.92 | 30.74 QP | 46.00 | -15.26 | 2.50 H | 16 | 11.78 | 18.96 |
| 5 | 611.22 | 31.65 QP | 46.00 | -14.35 | 2.00 H | 10 | 10.72 | 20.93 |
| 6 | 640.38 | 31.51 QP | 46.00 | -14.49 | 2.00 H | 213 | 10.26 | 21.25 |
| 7 | 720.08 | 30.66 QP | 46.00 | -15.34 | 2.00 H | 48 | 7.66 | 23.00 |
| 8 | 751.18 | 29.28 QP | 46.00 | -16.72 | 2.00 H | 48 | 5.37 | 23.91 |
| 9 | 760.90 | 29.23 QP | 46.00 | -16.77 | 2.00 H | 257 | 5.31 | 23.93 |
| 10 | 947.52 | 28.94 QP | 46.00 | -17.06 | 2.00 H | 257 | 1.70 | 27.24 |

| ANTENNA POLARITY & TEST DISTANCE: VERTICAL AT 3 M | | | | | | | | |
|---|-------------|-------------------------|----------------|-------------|--------------------|----------------------|------------------|--------------------------|
| No. | Freq. (MHz) | Emission Level (dBuV/m) | Limit (dBuV/m) | Margin (dB) | Antenna Height (m) | Table Angle (Degree) | Raw Value (dBuV) | Correction Factor (dB/m) |
| 1 | 35.83 | 36.34 QP | 40.00 | -3.66 | 1.00 V | 92 | 23.74 | 12.61 |
| 2 | 74.71 | 26.18 QP | 40.00 | -13.82 | 1.00 V | 213 | 15.36 | 10.82 |
| 3 | 111.64 | 29.28 QP | 43.50 | -14.22 | 1.00 V | 124 | 19.95 | 9.33 |
| 4 | 146.63 | 26.30 QP | 43.50 | -17.20 | 1.00 V | 181 | 13.65 | 12.66 |
| 5 | 255.49 | 28.70 QP | 46.00 | -17.30 | 1.00 V | 156 | 17.16 | 11.54 |
| 6 | 383.79 | 30.71 QP | 46.00 | -15.29 | 1.00 V | 99 | 14.56 | 16.15 |
| 7 | 603.45 | 29.62 QP | 46.00 | -16.38 | 1.00 V | 213 | 8.78 | 20.84 |
| 8 | 681.20 | 29.53 QP | 46.00 | -16.47 | 1.00 V | 99 | 7.53 | 22.00 |
| 9 | 720.08 | 31.79 QP | 46.00 | -14.21 | 1.00 V | 105 | 8.79 | 23.00 |
| 10 | 731.74 | 31.42 QP | 46.00 | -14.58 | 1.00 V | 168 | 8.06 | 23.36 |
| 11 | 760.90 | 29.95 QP | 46.00 | -16.05 | 1.00 V | 333 | 6.03 | 23.93 |
| 12 | 801.72 | 30.26 QP | 46.00 | -15.74 | 1.00 V | 181 | 6.26 | 24.01 |
| 13 | 863.93 | 30.40 QP | 46.00 | -15.60 | 1.00 V | 181 | 5.71 | 24.69 |
| 14 | 949.46 | 34.95 QP | 46.00 | -11.05 | 1.00 V | 168 | 7.62 | 27.33 |

- REMARKS:**
1. Emission level(dBuV/m)=Raw Value(dBuV) + Correction Factor(dB/m)
 2. Correction Factor(dB/m) = Antenna Factor (dB/m) + Cable Factor (dB)
 3. The other emission levels were very low against the limit.
 4. Margin value = Emission level – Limit value.

| EUT TEST CONDITION | | MEASUREMENT DETAIL | |
|--------------------------|-------------------------|----------------------|---------------|
| CHANNEL | Channel 78 | FREQUENCY RANGE | Below 1000MHz |
| MODULATION TYPE | GFSK | DETECTOR FUNCTION | Quasi-Peak |
| ENVIRONMENTAL CONDITIONS | 26deg. C, 65%RH, 991hPa | INPUT POWER (SYSTEM) | 120Vac, 60 Hz |
| TEST MODE | E | TESTED BY | Match Tsui |

| ANTENNA POLARITY & TEST DISTANCE: HORIZONTAL AT 3 M | | | | | | | | |
|---|-------------|-------------------------|----------------|-------------|--------------------|----------------------|------------------|--------------------------|
| No. | Freq. (MHz) | Emission Level (dBuV/m) | Limit (dBuV/m) | Margin (dB) | Antenna Height (m) | Table Angle (Degree) | Raw Value (dBuV) | Correction Factor (dB/m) |
| 1 | 76.65 | 28.16 QP | 40.00 | -11.84 | 1.50 H | 48 | 17.62 | 10.54 |
| 2 | 113.59 | 34.28 QP | 43.50 | -9.22 | 1.50 H | 67 | 24.78 | 9.50 |
| 3 | 152.46 | 33.91 QP | 43.50 | -9.59 | 2.50 H | 54 | 21.28 | 12.63 |
| 4 | 191.34 | 30.51 QP | 43.50 | -12.99 | 1.50 H | 48 | 20.01 | 10.50 |
| 5 | 210.78 | 36.34 QP | 43.50 | -7.16 | 1.50 H | 289 | 26.06 | 10.28 |
| 6 | 249.66 | 32.75 QP | 46.00 | -13.25 | 2.00 H | 130 | 21.19 | 11.56 |
| 7 | 457.66 | 31.51 QP | 46.00 | -14.49 | 1.00 H | 124 | 13.83 | 17.67 |
| 8 | 465.43 | 34.57 QP | 46.00 | -11.43 | 2.50 H | 149 | 16.72 | 17.85 |
| 9 | 521.80 | 33.06 QP | 46.00 | -12.94 | 1.50 H | 48 | 14.02 | 19.04 |
| 10 | 601.50 | 34.37 QP | 46.00 | -11.63 | 2.00 H | 346 | 13.55 | 20.82 |
| 11 | 731.74 | 32.00 QP | 46.00 | -14.00 | 2.00 H | 346 | 8.65 | 23.36 |
| 12 | 945.57 | 32.67 QP | 46.00 | -13.33 | 2.50 H | 149 | 5.52 | 27.14 |

| ANTENNA POLARITY & TEST DISTANCE: VERTICAL AT 3 M | | | | | | | | |
|---|-------------|-------------------------|----------------|-------------|--------------------|----------------------|------------------|--------------------------|
| No. | Freq. (MHz) | Emission Level (dBuV/m) | Limit (dBuV/m) | Margin (dB) | Antenna Height (m) | Table Angle (Degree) | Raw Value (dBuV) | Correction Factor (dB/m) |
| 1 | 115.53 | 33.88 QP | 43.50 | -9.62 | 1.00 V | 194 | 24.22 | 9.66 |
| 2 | 249.66 | 35.82 QP | 46.00 | -10.18 | 1.00 V | 327 | 24.26 | 11.56 |
| 3 | 455.71 | 33.49 QP | 46.00 | -12.51 | 1.00 V | 130 | 15.86 | 17.63 |
| 4 | 465.43 | 36.95 QP | 46.00 | -9.05 | 2.00 V | 54 | 19.10 | 17.85 |
| 5 | 512.08 | 31.88 QP | 46.00 | -14.12 | 1.00 V | 194 | 13.03 | 18.85 |
| 6 | 562.63 | 32.83 QP | 46.00 | -13.17 | 1.00 V | 92 | 12.93 | 19.90 |
| 7 | 733.69 | 33.70 QP | 46.00 | -12.30 | 2.00 V | 73 | 10.29 | 23.41 |
| 8 | 945.57 | 37.02 QP | 46.00 | -8.98 | 2.00 V | 54 | 9.88 | 27.14 |

- REMARKS:**
1. Emission level(dBuV/m)=Raw Value(dBuV) + Correction Factor(dB/m)
 2. Correction Factor(dB/m) = Antenna Factor (dB/m) + Cable Factor (dB)
 3. The other emission levels were very low against the limit.
 4. Margin value = Emission level – Limit value.

| EUT TEST CONDITION | | MEASUREMENT DETAIL | |
|--------------------------|-------------------------|----------------------|---------------|
| CHANNEL | Channel 78 | FREQUENCY RANGE | Below 1000MHz |
| MODULATION TYPE | GFSK | DETECTOR FUNCTION | Quasi-Peak |
| ENVIRONMENTAL CONDITIONS | 25deg. C, 67%RH, 991hPa | INPUT POWER (SYSTEM) | 120Vac, 60 Hz |
| TEST MODE | F | TESTED BY | Long Chen |

| ANTENNA POLARITY & TEST DISTANCE: HORIZONTAL AT 3 M | | | | | | | | |
|---|-------------|-------------------------|----------------|-------------|--------------------|----------------------|------------------|--------------------------|
| No. | Freq. (MHz) | Emission Level (dBuV/m) | Limit (dBuV/m) | Margin (dB) | Antenna Height (m) | Table Angle (Degree) | Raw Value (dBuV) | Correction Factor (dB/m) |
| 1 | 119.42 | 36.71 QP | 43.50 | -6.79 | 1.00 H | 118 | 26.72 | 9.99 |
| 2 | 199.12 | 25.86 QP | 43.50 | -17.64 | 1.00 H | 130 | 15.88 | 9.99 |
| 3 | 300.20 | 28.50 QP | 46.00 | -17.50 | 2.00 H | 29 | 13.99 | 14.52 |
| 4 | 387.68 | 31.23 QP | 46.00 | -14.77 | 1.00 H | 289 | 14.96 | 16.27 |
| 5 | 407.11 | 28.62 QP | 46.00 | -17.38 | 2.00 H | 99 | 11.84 | 16.78 |
| 6 | 953.35 | 34.16 QP | 46.00 | -11.84 | 2.00 H | 99 | 6.89 | 27.27 |

| ANTENNA POLARITY & TEST DISTANCE: VERTICAL AT 3 M | | | | | | | | |
|---|-------------|-------------------------|----------------|-------------|--------------------|----------------------|------------------|--------------------------|
| No. | Freq. (MHz) | Emission Level (dBuV/m) | Limit (dBuV/m) | Margin (dB) | Antenna Height (m) | Table Angle (Degree) | Raw Value (dBuV) | Correction Factor (dB/m) |
| 1 | 39.72 | 25.83 QP | 40.00 | -14.17 | 1.00 V | 301 | 12.01 | 13.82 |
| 2 | 74.71 | 26.19 QP | 40.00 | -13.81 | 1.00 V | 130 | 15.37 | 10.82 |
| 3 | 115.53 | 37.45 QP | 43.50 | -6.05 | 1.00 V | 168 | 27.79 | 9.66 |
| 4 | 129.14 | 29.59 QP | 43.50 | -13.91 | 1.00 V | 225 | 18.34 | 11.25 |
| 5 | 300.20 | 27.45 QP | 46.00 | -18.55 | 1.75 V | 105 | 12.94 | 14.52 |
| 6 | 615.11 | 27.41 QP | 46.00 | -18.59 | 1.00 V | 352 | 6.44 | 20.97 |
| 7 | 626.77 | 28.15 QP | 46.00 | -17.85 | 1.25 V | 162 | 7.05 | 21.10 |
| 8 | 681.20 | 28.09 QP | 46.00 | -17.91 | 1.00 V | 352 | 6.09 | 22.00 |
| 9 | 945.57 | 38.18 QP | 46.00 | -7.82 | 1.75 V | 105 | 11.04 | 27.14 |

- REMARKS:**
1. Emission level(dBuV/m)=Raw Value(dBuV) + Correction Factor(dB/m)
 2. Correction Factor(dB/m) = Antenna Factor (dB/m) + Cable Factor (dB)
 3. The other emission levels were very low against the limit.
 4. Margin value = Emission level – Limit value.

| EUT TEST CONDITION | | MEASUREMENT DETAIL | |
|--------------------------|-------------------------|----------------------|---------------|
| CHANNEL | Channel 78 | FREQUENCY RANGE | Below 1000MHz |
| MODULATION TYPE | GFSK | DETECTOR FUNCTION | Quasi-Peak |
| ENVIRONMENTAL CONDITIONS | 26deg. C, 65%RH, 991hPa | INPUT POWER (SYSTEM) | 120Vac, 60 Hz |
| TEST MODE | G | TESTED BY | Match Tsui |

| ANTENNA POLARITY & TEST DISTANCE: HORIZONTAL AT 3 M | | | | | | | | |
|---|-------------|-------------------------|----------------|-------------|--------------------|----------------------|------------------|--------------------------|
| No. | Freq. (MHz) | Emission Level (dBuV/m) | Limit (dBuV/m) | Margin (dB) | Antenna Height (m) | Table Angle (Degree) | Raw Value (dBuV) | Correction Factor (dB/m) |
| 1 | 113.59 | 30.49 QP | 43.50 | -13.01 | 1.50 H | 251 | 21.00 | 9.50 |
| 2 | 210.78 | 27.86 QP | 43.50 | -15.64 | 1.50 H | 111 | 17.58 | 10.28 |
| 3 | 249.66 | 32.81 QP | 46.00 | -13.19 | 1.00 H | 308 | 21.25 | 11.56 |
| 4 | 383.79 | 31.04 QP | 46.00 | -14.96 | 2.00 H | 232 | 14.89 | 16.15 |
| 5 | 457.66 | 30.55 QP | 46.00 | -15.45 | 1.50 H | 295 | 12.87 | 17.67 |
| 6 | 465.43 | 36.55 QP | 46.00 | -9.45 | 2.00 H | 219 | 18.71 | 17.85 |
| 7 | 584.01 | 30.53 QP | 46.00 | -15.47 | 1.00 H | 92 | 10.11 | 20.42 |
| 8 | 601.50 | 35.40 QP | 46.00 | -10.60 | 2.00 H | 257 | 14.58 | 20.82 |
| 9 | 751.18 | 33.19 QP | 46.00 | -12.81 | 1.50 H | 346 | 9.28 | 23.91 |
| 10 | 801.72 | 32.53 QP | 46.00 | -13.47 | 1.50 H | 251 | 8.52 | 24.01 |
| 11 | 865.87 | 30.22 QP | 46.00 | -15.78 | 2.00 H | 244 | 5.51 | 24.71 |
| 12 | 945.57 | 30.62 QP | 46.00 | -15.38 | 2.00 H | 219 | 3.47 | 27.14 |

| ANTENNA POLARITY & TEST DISTANCE: VERTICAL AT 3 M | | | | | | | | |
|---|-------------|-------------------------|----------------|-------------|--------------------|----------------------|------------------|--------------------------|
| No. | Freq. (MHz) | Emission Level (dBuV/m) | Limit (dBuV/m) | Margin (dB) | Antenna Height (m) | Table Angle (Degree) | Raw Value (dBuV) | Correction Factor (dB/m) |
| 1 | 30.00 | 26.63 QP | 40.00 | -13.37 | 1.00 V | 333 | 14.96 | 11.67 |
| 2 | 113.59 | 30.53 QP | 43.50 | -12.97 | 1.00 V | 80 | 21.04 | 9.50 |
| 3 | 249.66 | 30.54 QP | 46.00 | -15.46 | 1.00 V | 80 | 18.97 | 11.56 |
| 4 | 457.66 | 33.10 QP | 46.00 | -12.90 | 1.00 V | 263 | 15.42 | 17.67 |
| 5 | 465.43 | 34.09 QP | 46.00 | -11.91 | 1.00 V | 219 | 16.24 | 17.85 |
| 6 | 515.97 | 30.70 QP | 46.00 | -15.30 | 1.50 V | 99 | 11.77 | 18.93 |
| 7 | 601.50 | 33.13 QP | 46.00 | -12.87 | 1.00 V | 295 | 12.31 | 20.82 |
| 8 | 751.18 | 31.71 QP | 46.00 | -14.29 | 1.00 V | 42 | 7.80 | 23.91 |
| 9 | 799.78 | 30.99 QP | 46.00 | -15.01 | 1.00 V | 86 | 7.00 | 23.98 |
| 10 | 945.57 | 33.14 QP | 46.00 | -12.86 | 1.00 V | 219 | 6.00 | 27.14 |

- REMARKS:**
1. Emission level(dBuV/m)=Raw Value(dBuV) + Correction Factor(dB/m)
 2. Correction Factor(dB/m) = Antenna Factor (dB/m) + Cable Factor (dB)
 3. The other emission levels were very low against the limit.
 4. Margin value = Emission level – Limit value.



| EUT TEST CONDITION | | MEASUREMENT DETAIL | |
|----------------------|---------------|--------------------------|----------------------------|
| CHANNEL | Channel 0 | FREQUENCY RANGE | 1 ~ 25GHz |
| MODULATION TYPE | GFSK | DETECTOR FUNCTION | Peak (PK) Average (AV) |
| INPUT POWER (SYSTEM) | 120Vac, 60 Hz | ENVIRONMENTAL CONDITIONS | 23deg. C, 68%RH, 991hPa |
| TEST MODE | E | TESTED BY | Morgan Chen |

| ANTENNA POLARITY & TEST DISTANCE: HORIZONTAL AT 3 M | | | | | | | | |
|---|-------------|-------------------------|----------------|-------------|--------------------|----------------------|------------------|--------------------------|
| No. | Freq. (MHz) | Emission Level (dBuV/m) | Limit (dBuV/m) | Margin (dB) | Antenna Height (m) | Table Angle (Degree) | Raw Value (dBuV) | Correction Factor (dB/m) |
| 1 | 1601.00 | 45.11 PK | 74.00 | -28.89 | 1.13 H | 91 | 15.86 | 29.25 |
| 1 | 1601.00 | 28.92 AV | 54.00 | -25.08 | 1.13 H | 91 | -0.33 | 29.25 |
| 2 | 2390.00 | 38.82 PK | 74.00 | -35.18 | 1.09 H | 36 | 7.33 | 31.49 |
| 2 | 2390.00 | 32.41 AV | 54.00 | -21.59 | 1.09 H | 36 | 0.92 | 31.49 |
| 3 | *2402.00 | 87.82 PK | | | 1.08 H | 352 | 56.28 | 31.54 |
| 3 | *2402.00 | 57.82 AV | | | 1.08 H | 352 | 26.28 | 31.54 |
| 4 | 4804.00 | 47.32 PK | 74.00 | -26.68 | 1.01 H | 32 | 9.84 | 37.48 |
| 4 | 4804.00 | 17.32 AV | 54.00 | -36.68 | 1.01 H | 32 | -20.16 | 37.48 |

| ANTENNA POLARITY & TEST DISTANCE: VERTICAL AT 3 M | | | | | | | | |
|---|-------------|-------------------------|----------------|-------------|--------------------|----------------------|------------------|--------------------------|
| No. | Freq. (MHz) | Emission Level (dBuV/m) | Limit (dBuV/m) | Margin (dB) | Antenna Height (m) | Table Angle (Degree) | Raw Value (dBuV) | Correction Factor (dB/m) |
| 1 | 1601.00 | 45.60 PK | 74.00 | -28.40 | 1.07 V | 19 | 16.35 | 29.25 |
| 1 | 1601.00 | 29.01 AV | 54.00 | -24.99 | 1.07 V | 19 | -0.24 | 29.25 |
| 2 | 2390.00 | 35.65 PK | 74.00 | -38.35 | 1.33 V | 312 | 4.16 | 31.49 |
| 2 | 2390.00 | 30.25 AV | 54.00 | -23.75 | 1.33 V | 312 | -1.24 | 31.49 |
| 3 | *2402.00 | 84.66 PK | | | 1.16 V | 204 | 53.12 | 31.54 |
| 3 | *2402.00 | 54.66 AV | | | 1.16 V | 204 | 23.12 | 31.54 |
| 4 | 4804.00 | 47.10 PK | 74.00 | -26.90 | 1.08 V | 315 | 9.62 | 37.48 |
| 4 | 4804.00 | 17.10 AV | 54.00 | -36.90 | 1.08 V | 315 | -20.38 | 37.48 |

- REMARKS:**
1. Emission level (dBuV/m) = Raw Value (dBuV) + Correction Factor (dB/m).
 2. Correction Factor (dB/m) = Antenna Factor (dB/m) + Cable Factor (dB).
 3. The other emission levels were very low against the limit.
 4. Margin value = Emission level – Limit value.
 5. The DH5 packet was the worse case duty cycle for a transmit dwell time on a channel, based upon bluetooth theory the transmitter is on 0.625 * 5 per 247 ms per channel. Therefore, the duty cycle be equal to $20\log(3.125/100) = -30$ dB.
 6. Average value = peak reading – 20log (duty cycle).



| EUT TEST CONDITION | | MEASUREMENT DETAIL | |
|----------------------|---------------|--------------------------|----------------------------|
| CHANNEL | Channel 39 | FREQUENCY RANGE | 1 ~ 25GHz |
| MODULATION TYPE | GFSK | DETECTOR FUNCTION | Peak (PK) Average (AV) |
| INPUT POWER (SYSTEM) | 120Vac, 60 Hz | ENVIRONMENTAL CONDITIONS | 23deg. C, 68%RH, 991hPa |
| TEST MODE | E | TESTED BY | Morgan Chen |

| ANTENNA POLARITY & TEST DISTANCE: HORIZONTAL AT 3 M | | | | | | | | |
|---|-------------|-------------------------|----------------|-------------|--------------------|----------------------|------------------|--------------------------|
| No. | Freq. (MHz) | Emission Level (dBuV/m) | Limit (dBuV/m) | Margin (dB) | Antenna Height (m) | Table Angle (Degree) | Raw Value (dBuV) | Correction Factor (dB/m) |
| 1 | 1627.00 | 45.88 PK | 74.00 | -28.12 | 1.06 H | 352 | 16.60 | 29.28 |
| 1 | 1627.00 | 29.12 AV | 54.00 | -24.88 | 1.06 H | 352 | -0.16 | 29.28 |
| 2 | *2441.00 | 90.75 PK | | | 1.24 H | 309 | 59.03 | 31.72 |
| 2 | *2441.00 | 60.75 AV | | | 1.24 H | 309 | 29.03 | 31.72 |
| 3 | 4882.00 | 47.55 PK | 74.00 | -26.45 | 1.05 H | 15 | 9.88 | 37.67 |
| 3 | 4882.00 | 17.55 AV | 54.00 | -36.45 | 1.05 H | 15 | -20.12 | 37.67 |

| ANTENNA POLARITY & TEST DISTANCE: VERTICAL AT 3 M | | | | | | | | |
|---|-------------|-------------------------|----------------|-------------|--------------------|----------------------|------------------|--------------------------|
| No. | Freq. (MHz) | Emission Level (dBuV/m) | Limit (dBuV/m) | Margin (dB) | Antenna Height (m) | Table Angle (Degree) | Raw Value (dBuV) | Correction Factor (dB/m) |
| 1 | 1627.00 | 45.71 PK | 74.00 | -28.29 | 1.06 V | 32 | 16.43 | 29.28 |
| 1 | 1627.00 | 29.18 AV | 54.00 | -24.82 | 1.06 V | 32 | -0.10 | 29.28 |
| 2 | *2441.00 | 87.55 PK | | | 1.26 V | 302 | 55.83 | 31.72 |
| 2 | *2441.00 | 57.55 AV | | | 1.26 V | 302 | 25.83 | 31.72 |
| 3 | 4882.00 | 47.11 PK | 74.00 | -26.89 | 1.03 V | 313 | 9.44 | 37.67 |
| 3 | 4882.00 | 17.11 AV | 54.00 | -36.89 | 1.03 V | 313 | -20.56 | 37.67 |

- REMARKS:**
1. Emission level (dBuV/m) = Raw Value (dBuV) + Correction Factor (dB/m).
 2. Correction Factor (dB/m) = Antenna Factor (dB/m) + Cable Factor (dB).
 3. The other emission levels were very low against the limit.
 4. Margin value = Emission level – Limit value.
 5. The DH5 packet was the worse case duty cycle for a transmit dwell time on a channel, based upon bluetooth theory the transmitter is on 0.625 * 5 per 247 ms per channel. Therefore, the duty cycle be equal to $20\log(3.125/100) = -30$ dB.
 6. Average value = peak reading – $20\log(\text{duty cycle})$.

| EUT TEST CONDITION | | MEASUREMENT DETAIL | |
|----------------------|---------------|--------------------------|----------------------------|
| CHANNEL | Channel 78 | FREQUENCY RANGE | 1 ~ 25GHz |
| MODULATION TYPE | GFSK | DETECTOR FUNCTION | Peak (PK) Average (AV) |
| INPUT POWER (SYSTEM) | 120Vac, 60 Hz | ENVIRONMENTAL CONDITIONS | 23deg. C, 68%RH, 991hPa |
| TEST MODE | E | TESTED BY | Morgan Chen |

| ANTENNA POLARITY & TEST DISTANCE: HORIZONTAL AT 3 M | | | | | | | | |
|---|-------------|-------------------------|----------------|-------------|--------------------|----------------------|------------------|--------------------------|
| No. | Freq. (MHz) | Emission Level (dBuV/m) | Limit (dBuV/m) | Margin (dB) | Antenna Height (m) | Table Angle (Degree) | Raw Value (dBuV) | Correction Factor (dB/m) |
| 1 | 1653.00 | 45.55 PK | 74.00 | -28.45 | 1.09 H | 35 | 16.24 | 29.31 |
| 1 | 1653.00 | 29.35 AV | 54.00 | -24.65 | 1.09 H | 35 | 0.04 | 29.31 |
| 2 | *2480.00 | 92.37 PK | | | 1.01 H | 341 | 60.47 | 31.90 |
| 2 | *2480.00 | 62.37 AV | | | 1.01 H | 341 | 30.47 | 31.90 |
| 3 | 2483.50 | 43.12 PK | 74.00 | -30.88 | 1.03 H | 311 | 11.21 | 31.91 |
| 3 | 2483.50 | 35.33 AV | 54.00 | -18.67 | 1.03 H | 311 | 3.42 | 31.91 |
| 4 | 4960.00 | 48.55 PK | 74.00 | -25.45 | 1.05 H | 13 | 10.72 | 37.83 |
| 4 | 4960.00 | 18.55 AV | 54.00 | -35.45 | 1.05 H | 13 | -19.28 | 37.83 |

| ANTENNA POLARITY & TEST DISTANCE: VERTICAL AT 3 M | | | | | | | | |
|---|-------------|-------------------------|----------------|-------------|--------------------|----------------------|------------------|--------------------------|
| No. | Freq. (MHz) | Emission Level (dBuV/m) | Limit (dBuV/m) | Margin (dB) | Antenna Height (m) | Table Angle (Degree) | Raw Value (dBuV) | Correction Factor (dB/m) |
| 1 | 1653.00 | 45.71 PK | 74.00 | -28.29 | 1.03 V | 32 | 16.40 | 29.31 |
| 1 | 1653.00 | 29.33 AV | 54.00 | -24.67 | 1.03 V | 32 | 0.02 | 29.31 |
| 2 | *2480.00 | 89.11 PK | | | 1.13 V | 321 | 57.21 | 31.90 |
| 2 | *2480.00 | 59.11 AV | | | 1.13 V | 321 | 27.21 | 31.90 |
| 3 | 2483.50 | 40.11 PK | 74.00 | -33.89 | 1.03 V | 318 | 8.20 | 31.91 |
| 3 | 2483.50 | 34.43 AV | 54.00 | -19.57 | 1.03 V | 318 | 2.52 | 31.91 |
| 4 | 4960.00 | 48.13 PK | 74.00 | -25.87 | 1.03 V | 321 | 10.30 | 37.83 |
| 4 | 4960.00 | 18.13 AV | 54.00 | -35.87 | 1.03 V | 321 | -19.70 | 37.83 |

- REMARKS:**
1. Emission level (dBuV/m) = Raw Value (dBuV) + Correction Factor (dB/m).
 2. Correction Factor (dB/m) = Antenna Factor (dB/m) + Cable Factor (dB).
 3. The other emission levels were very low against the limit.
 4. Margin value = Emission level – Limit value.
 5. The DH5 packet was the worse case duty cycle for a transmit dwell time on a channel, based upon bluetooth theory the transmitter is on 0.625 * 5 per 247 ms per channel. Therefore, the duty cycle be equal to $20\log(3.125/100) = -30$ dB.
 6. Average value = peak reading – $20\log(\text{duty cycle})$.



4.3 NUMBER OF HOPPING FREQUENCY USED

4.3.1 LIMIT OF HOPPING FREQUENCY USED

At least 15 channels frequencies, and should be equally spaced.

4.3.2 TEST INSTRUMENTS

| DESCRIPTION & MANUFACTURER | MODEL NO. | SERIAL NO. | CALIBRATED UNTIL |
|----------------------------|-----------|------------|------------------|
| SPECTRUM ANALYZER | FSP40 | 100040 | Jun. 07, 2007 |

NOTE: The calibration interval of the above test instruments is 12 months. And the calibrations are traceable to NML/ROC and NIST/USA.

4.3.3 TEST PROCEDURES

- a. Check the calibration of the measuring instrument (SA) using either an internal calibrator or a known signal from an external generator.
- b. Turn on the EUT and connect its antenna terminal to measurement via a low loss cable. Then set it to any one measured frequency within its operating range and make sure the instrument is operated in its linear range.
- c. Set the SA on MaxHold Mode, and then keep the EUT in hopping mode. Record all the signals from each channel until each one has been recorded.
- d. Set the SA on View mode and then plot the result on SA screen.
- e. Repeat above procedures until all frequencies measured were complete.

4.3.4 DEVIATION FROM TEST STANDARD

No deviation.

4.3.5 TEST SETUP

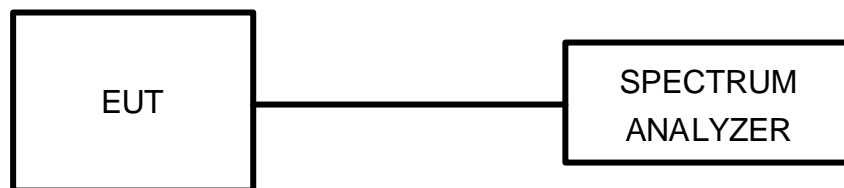

4.3.6 TEST RESULTS

There are 79 hopping frequencies in the hopping mode. Please refer to next two pages for the test result. On the plots, it shows that the hopping frequencies are equally spaced.

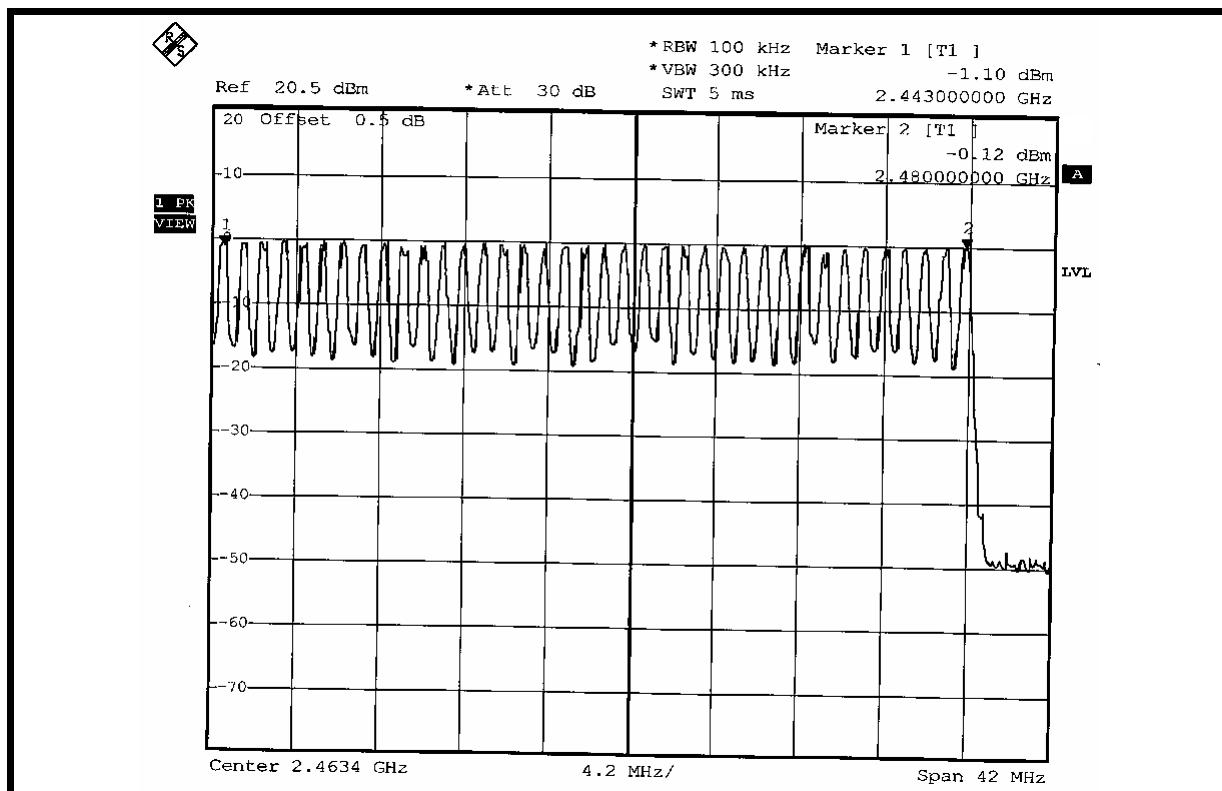
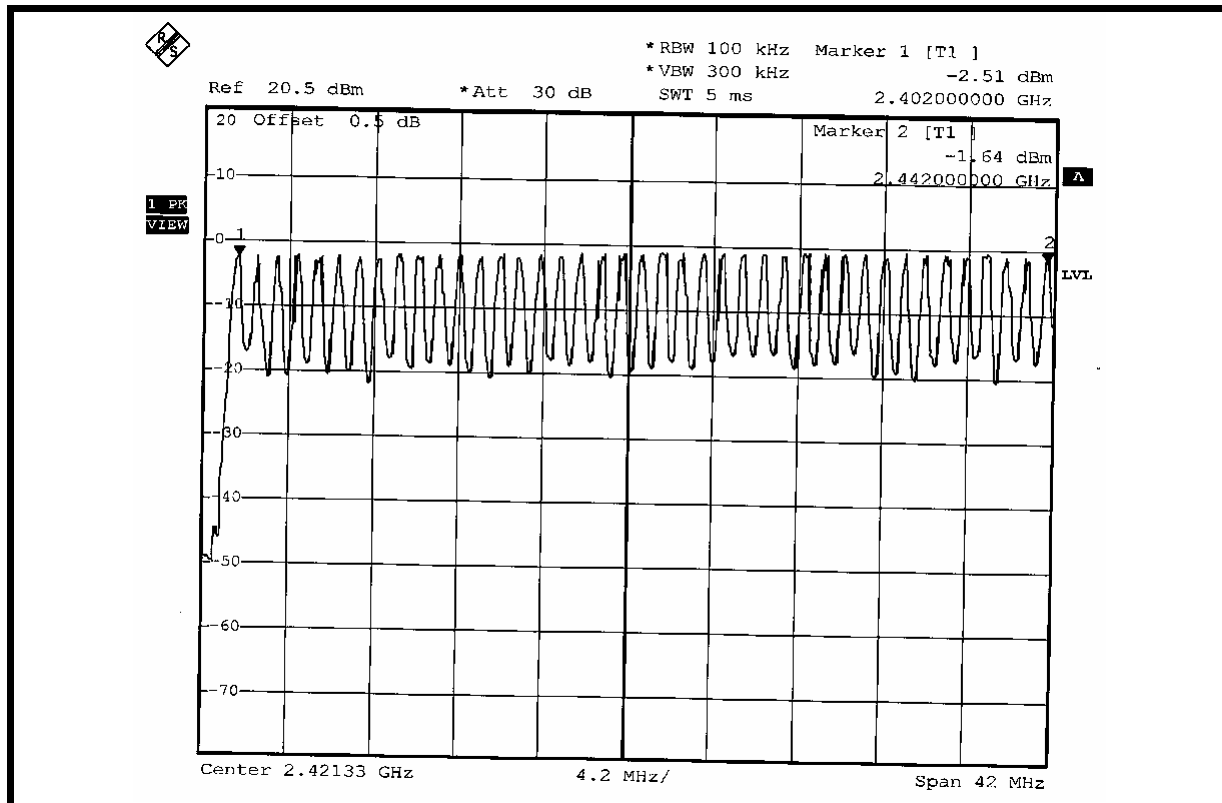



4.4 DWELL TIME ON EACH CHANNEL

4.4.1 LIMIT OF DWELL TIME USED

The average time of occupancy on any channel shall not be greater than 0.4 seconds within a period of 0.4 seconds multiplied by the number of hopping channels employed.

4.4.2 TEST INSTRUMENTS

| DESCRIPTION & MANUFACTURER | MODEL NO. | SERIAL NO. | CALIBRATED UNTIL |
|----------------------------|-----------|------------|------------------|
| SPECTRUM ANALYZER | FSP40 | 100040 | Jun. 07, 2007 |

NOTES: The calibration interval of the above test instruments is 12 months. And the calibrations are traceable to NML/ROC and NIST/USA.

4.4.3 TEST PROCEDURES

- a. Check the calibration of the measuring instrument (SA) using either an internal calibrator or a known signal from an external generator.
- b. Turn on the EUT and connect its antenna terminal to measurement via a low loss cable. Then set it to any one measured frequency within its operating range and make sure the instrument is operated in its linear range.
- c. Adjust the center frequency of SA on any frequency be measured and set SA to zero span mode. And then, set RBW and VBW of spectrum analyzer to proper value.
- d. Measure the time duration of one transmission on the measured frequency. And then plot the result with time difference of this time duration.
- e. Repeat above procedures until all different time-slot modes have been completed.

4.4.4 DEVIATION FROM TEST STANDARD

No deviation.

4.4.5 TEST SETUP

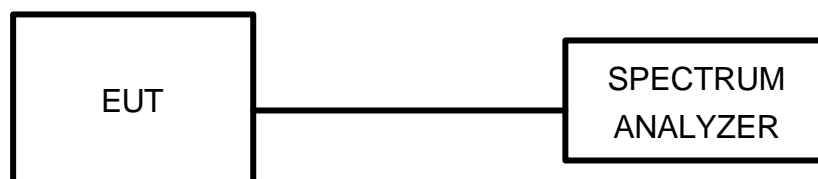

4.4.6 TEST RESULTS

| MODE | NUMBER OF TRANSMISSION IN A 31.6 (79HOPPING*0.4) | LENGTH OF TRANSMISSION TIME (msec) | RESULT (msec) | LIMIT (msec) |
|------|--|------------------------------------|---------------|--------------|
| DH1 | 50 (times / 5 sec) * 6.32 = 316.00 times | 0.474 | 149.784 | 400 |
| DH3 | 25 (times / 5 sec) * 6.32 = 158.00 times | 1.728 | 273.024 | 400 |
| DH5 | 18 (times / 5 sec) * 6.32 = 113.76 times | 3.040 | 345.830 | 400 |

NOTE: Test plots of the transmitting time slot are shown on next 3 pages.

DH1

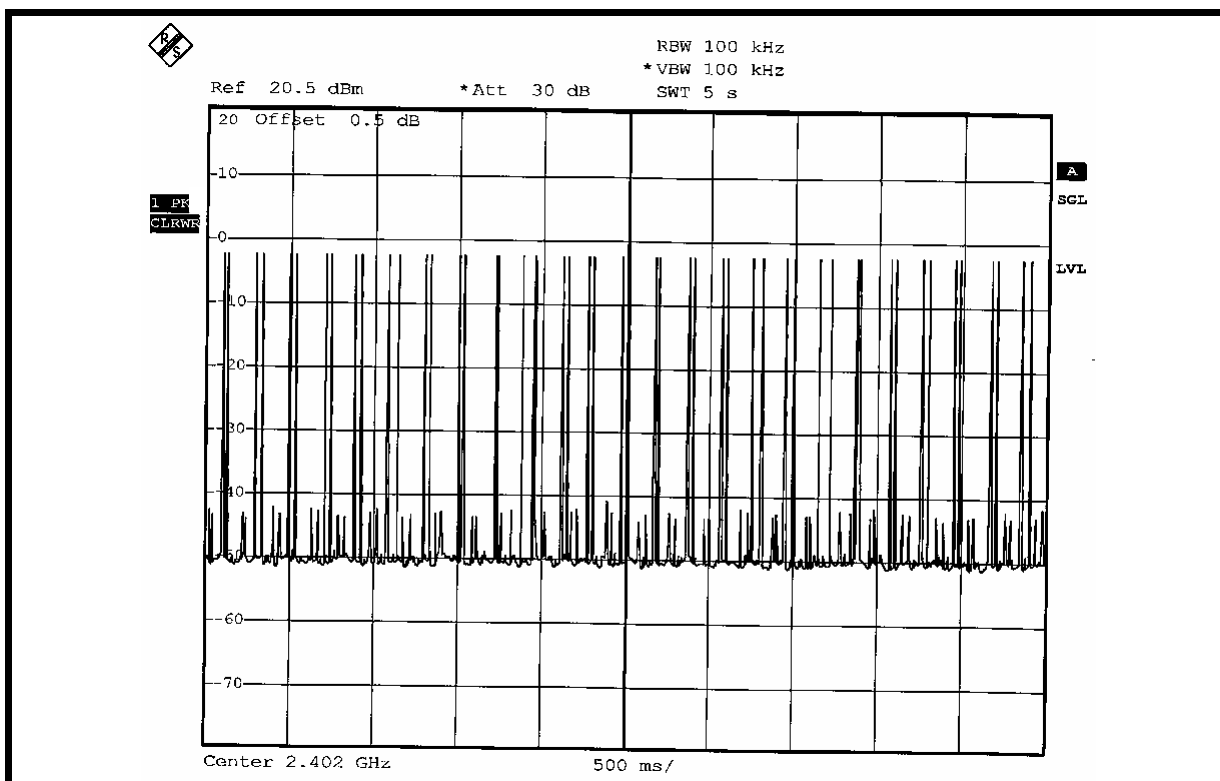
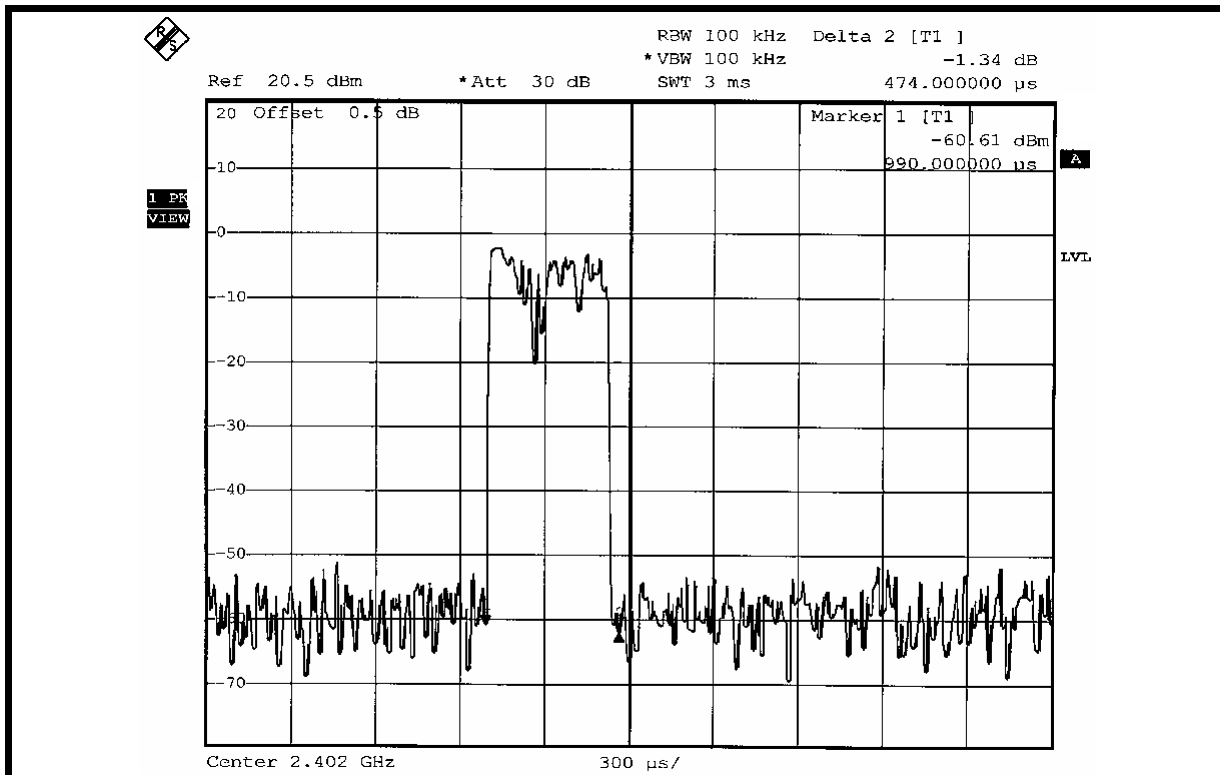

DH3

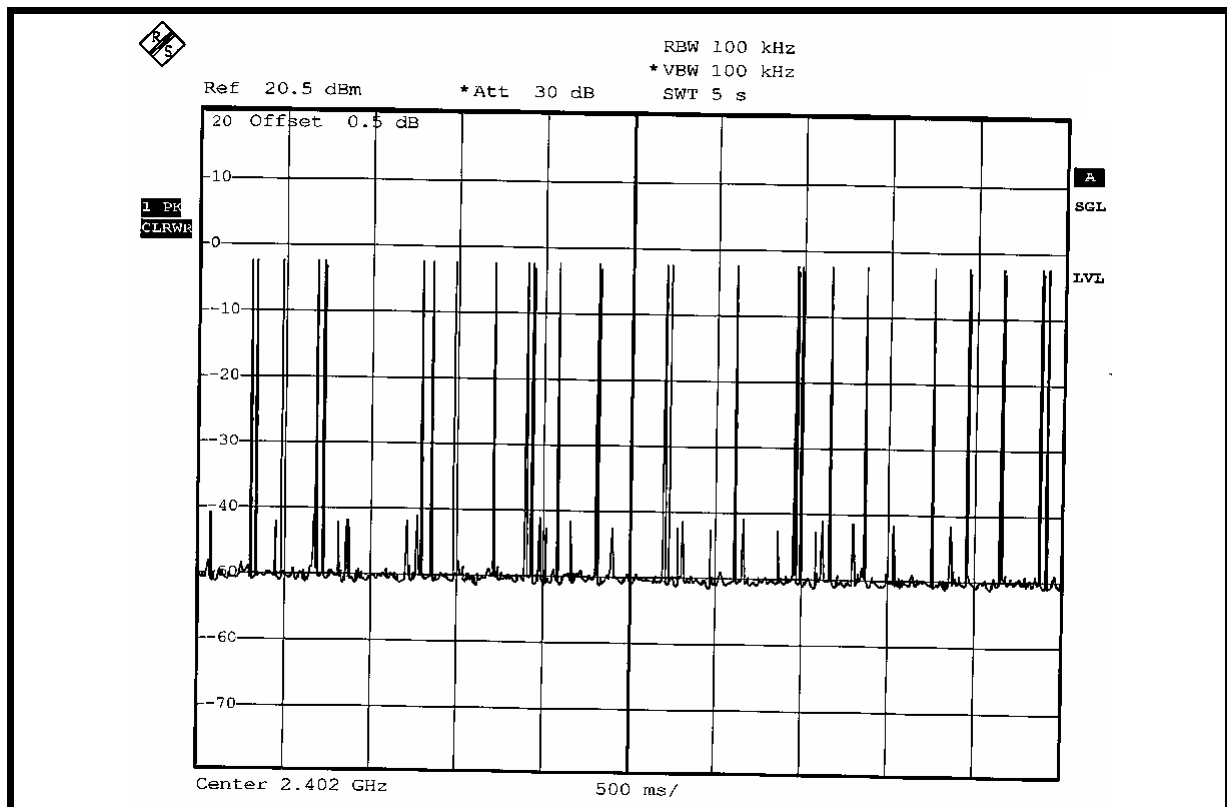
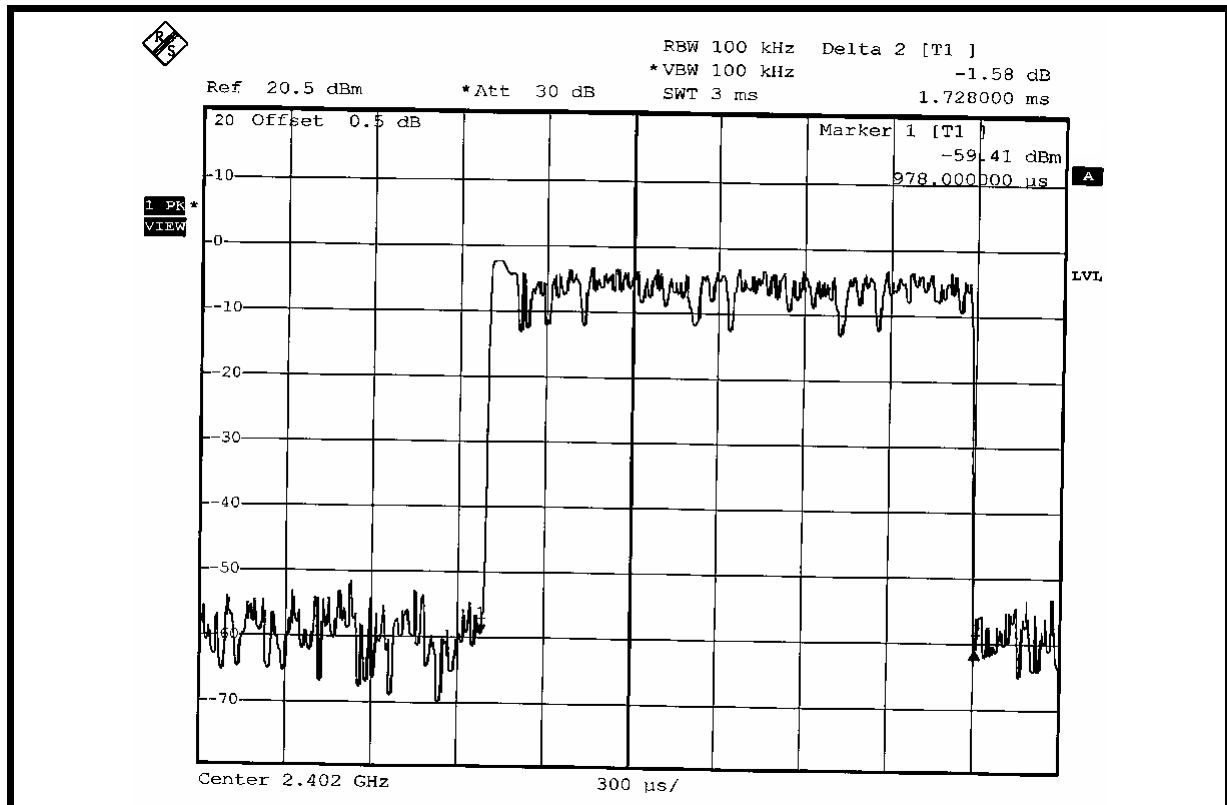

DH5

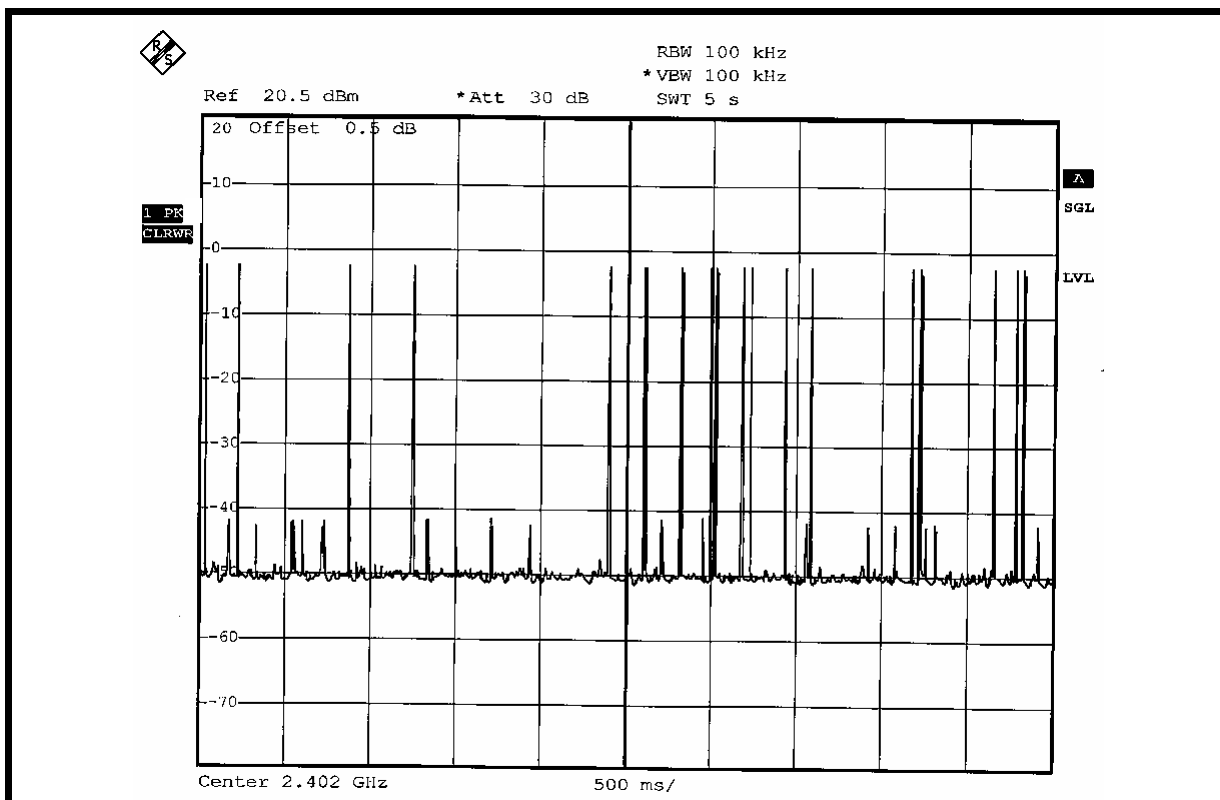
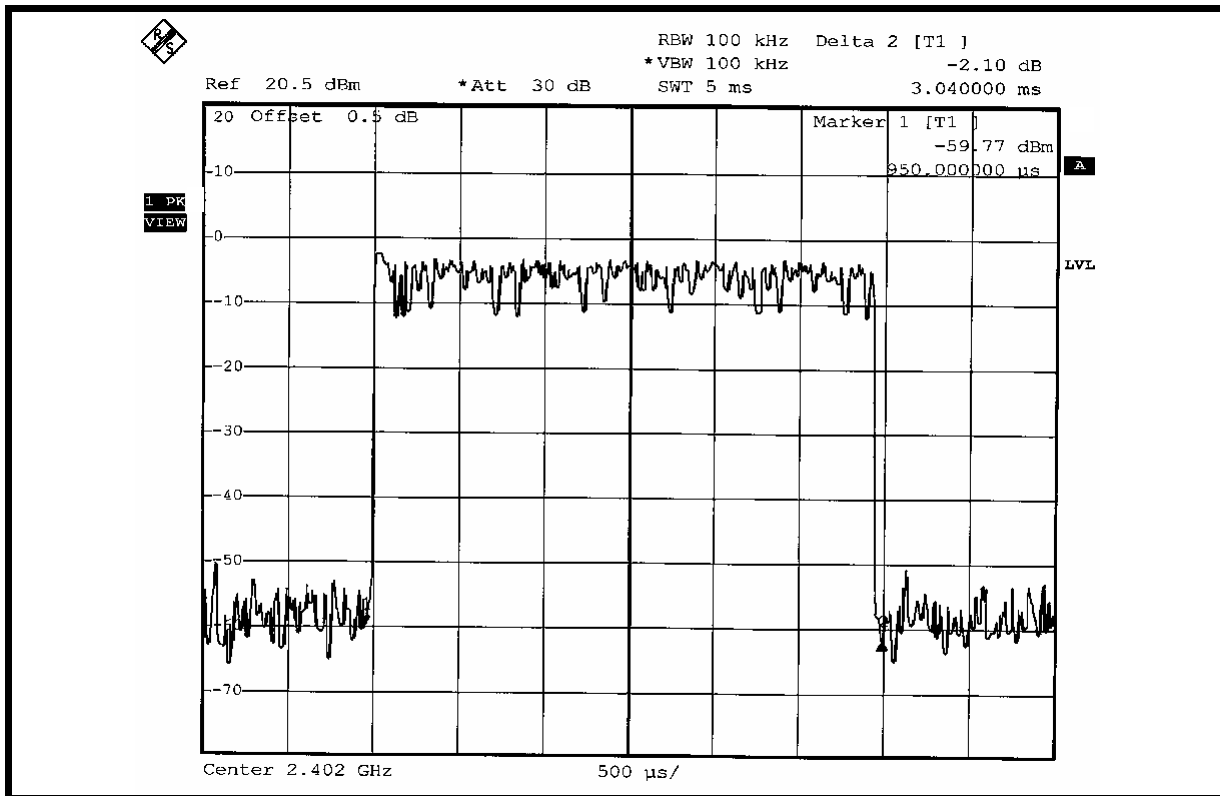



4.5 CHANNEL BANDWIDTH

4.5.1 LIMITS OF CHANNEL BANDWIDTH

For frequency hopping system operating in the 2400-2483.5MHz, If the 20dB bandwidth of hopping channel is greater than 25kHz, the 20dB bandwidth of hopping channel shall be a minimum limit for the hopping channel separation.

4.5.2 TEST INSTRUMENTS

| DESCRIPTION & MANUFACTURER | MODEL NO. | SERIAL NO. | CALIBRATED UNTIL |
|----------------------------|-----------|------------|------------------|
| SPECTRUM ANALYZER | FSP40 | 100040 | Jun. 07, 2007 |

NOTE: The calibration interval of the above test instruments is 12 months. And the calibrations are traceable to NML/ROC and NIST/USA.

4.5.3 TEST PROCEDURE

- a. Check the calibration of the measuring instrument using either an internal calibrator or a known signal from an external generator.
- b. Turn on the EUT and connect it to measurement instrument. Then set it to any one convenient frequency within its operating range. Set a reference level on the measuring instrument equal to the highest peak value.
- c. Measure the frequency difference of two frequencies that were attenuated 20dB from the reference level. Record the frequency difference as the emission bandwidth.
- d. Repeat above procedures until all frequencies measured were complete.

4.5.4 DEVIATION FROM TEST STANDARD

No deviation.

4.5.5 TEST SETUP

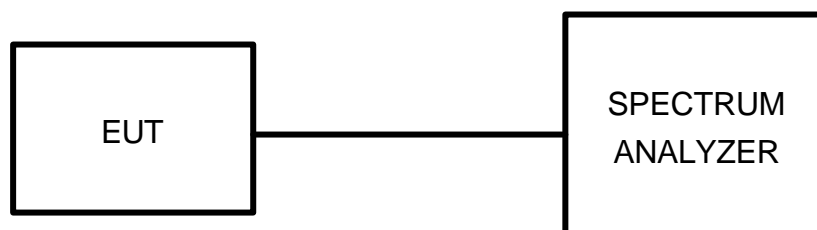

4.5.6 EUT OPERATING CONDITION

The software provided by client enabled the EUT to transmit and receive data at lowest, middle and highest channel frequencies individually.

4.5.7 TEST RESULTS

| | | | |
|-----------------------------|---------------|---------------------------------|-------------------------|
| MODULATION TYPE | GFSK | ENVIRONMENTAL CONDITIONS | 23deg. C, 68%RH, 991hPa |
| INPUT POWER (SYSTEM) | 120Vac, 60 Hz | TESTED BY | Long Chen |

| CHANNEL | CHANNEL FREQUENCY (MHz) | 20dB BANDWIDTH (MHz) |
|---------|-------------------------|----------------------|
| 0 | 2402 | 0.961 |
| 39 | 2441 | 0.966 |
| 78 | 2480 | 0.966 |

CH 0

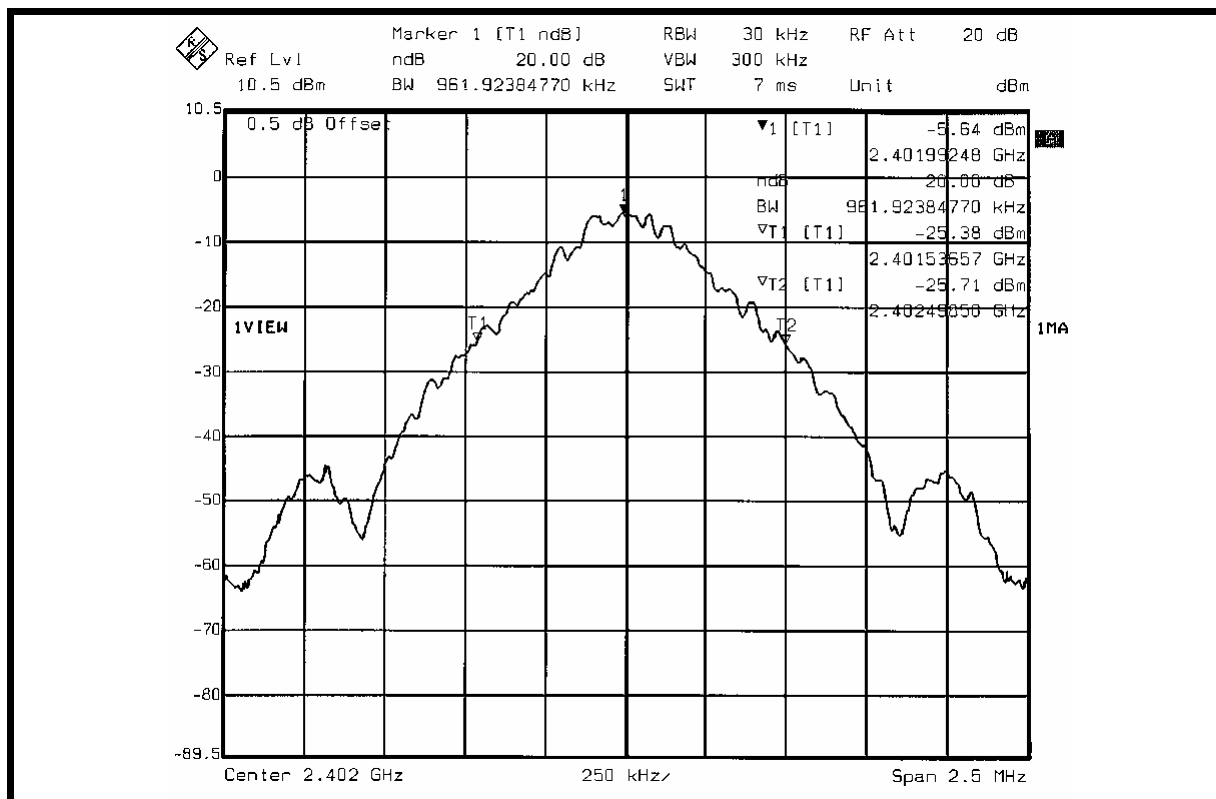

CH 39

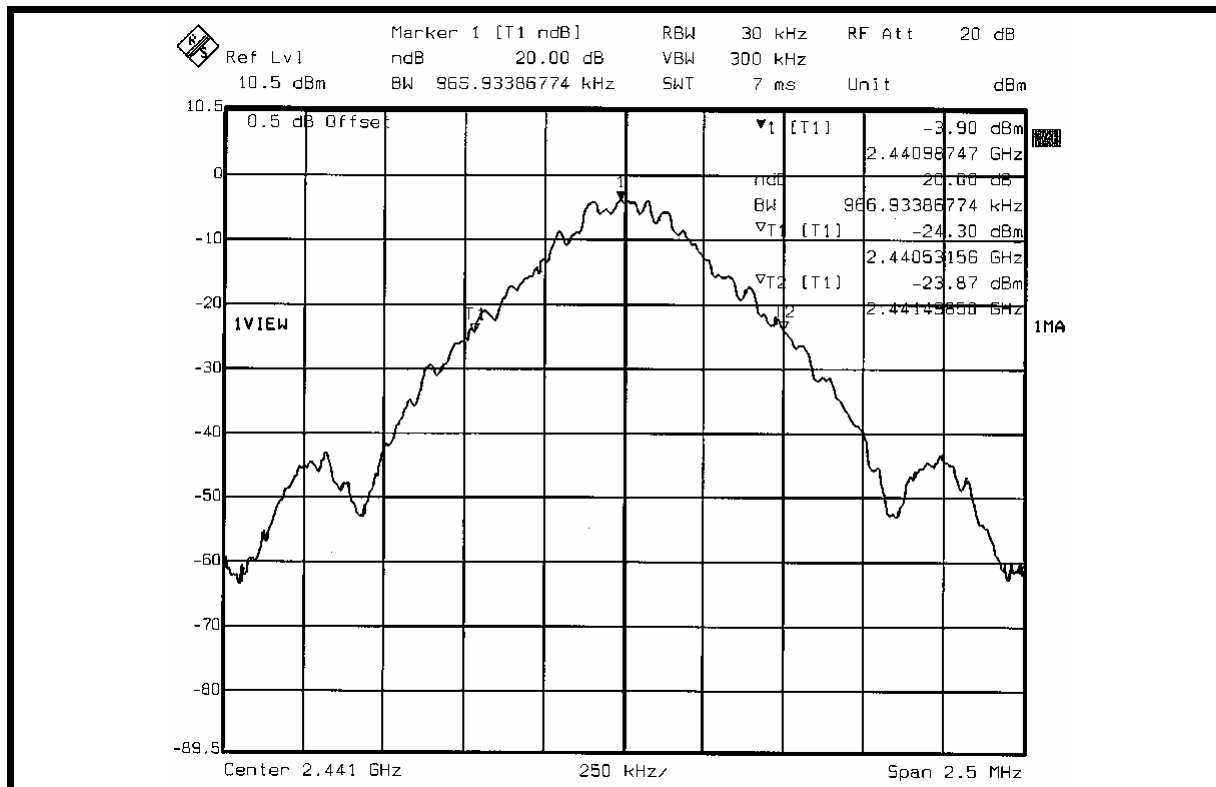

CH 78

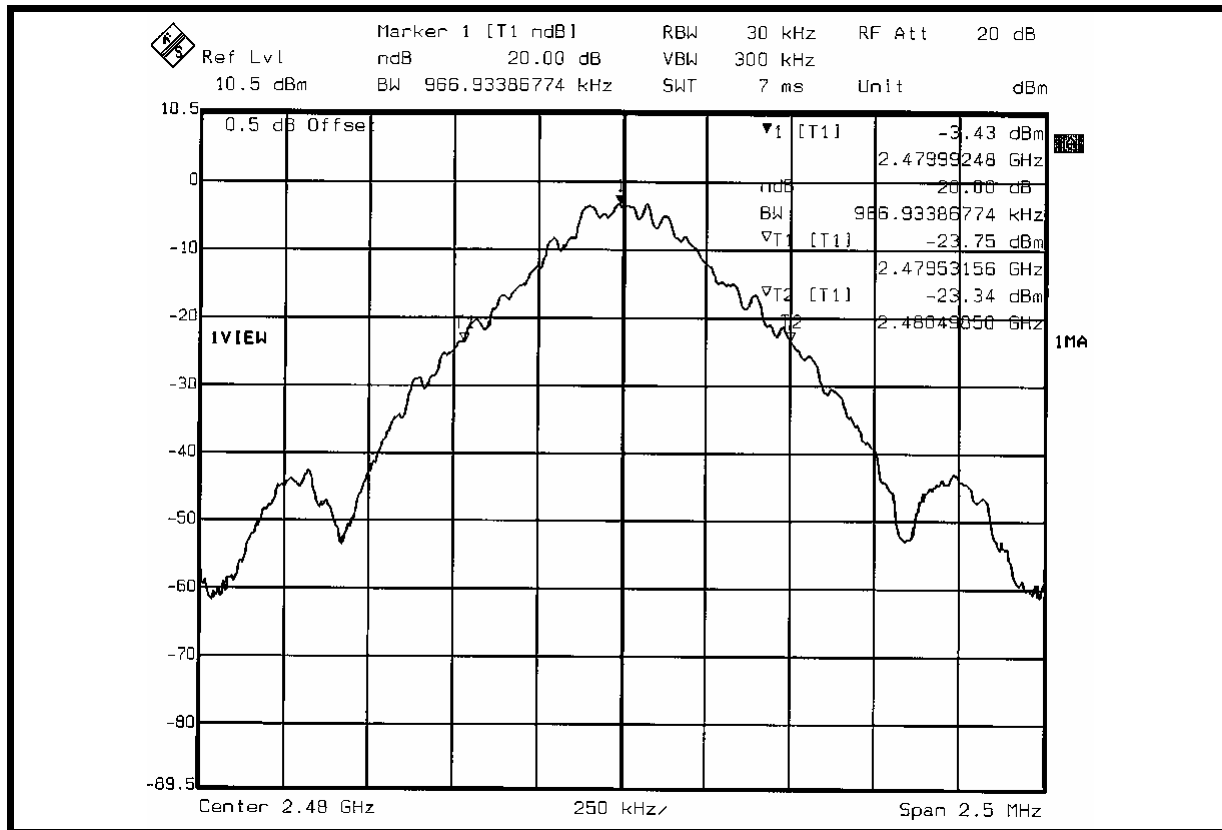



4.6 HOPPING CHANNEL SEPARATION

4.6.1 LIMIT OF HOPPING CHANNEL SEPARATION

At least 25kHz or 20dB bandwidth (whichever is greater).

4.6.2 TEST INSTRUMENTS

| DESCRIPTION & MANUFACTURER | MODEL NO. | SERIAL NO. | CALIBRATED UNTIL |
|----------------------------|-----------|------------|------------------|
| SPECTRUM ANALYZER | FSP40 | 100040 | Jun. 07, 2007 |

NOTES: The calibration interval of the above test instruments is 12 months. And the calibrations are traceable to NML/ROC and NIST/USA.

4.6.3 TEST PROCEDURES

1. Check the calibration of the measuring instrument using either an internal calibrator or a known signal from an external generator.
2. Turn on the EUT and connect it to measurement instrument. Then set it to any one convenient frequency within its operating range.
3. By using the MaxHold function record the separation of two adjacent channels.
4. Measure the frequency difference of these two adjacent channels by SA MARK function. And then plot the result on SA screen.
5. Repeat above procedures until all frequencies measured were complete.

4.6.4 DEVIATION FROM TEST STANDARD

No deviation

4.6.5 TEST SETUP

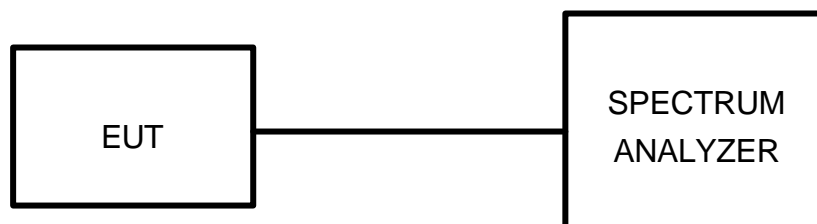

4.6.6 TEST RESULTS

| | | | |
|-----------------------------|---------------|---------------------------------|-------------------------|
| MODULATION TYPE | GFSK | ENVIRONMENTAL CONDITIONS | 23deg. C, 68%RH, 991hPa |
| INPUT POWER (SYSTEM) | 120Vac, 60 Hz | TESTED BY | Long Chen |

| CHANNEL | FREQUENCY (MHz) | ADJACENT CHANNEL SEPARATION (MHz) | MINIMUM LIMIT (MHz) | PASS / FAIL |
|---------|-----------------|-----------------------------------|---------------------|-------------|
| 0 | 2402 | 1.010 | 0.961 | PASS |
| 39 | 2441 | 1.005 | 0.966 | PASS |
| 78 | 2480 | 1.003 | 0.966 | PASS |

NOTE: The minimum limit is 20dB bandwidth. Test results please refer to next two pages.

CH 0

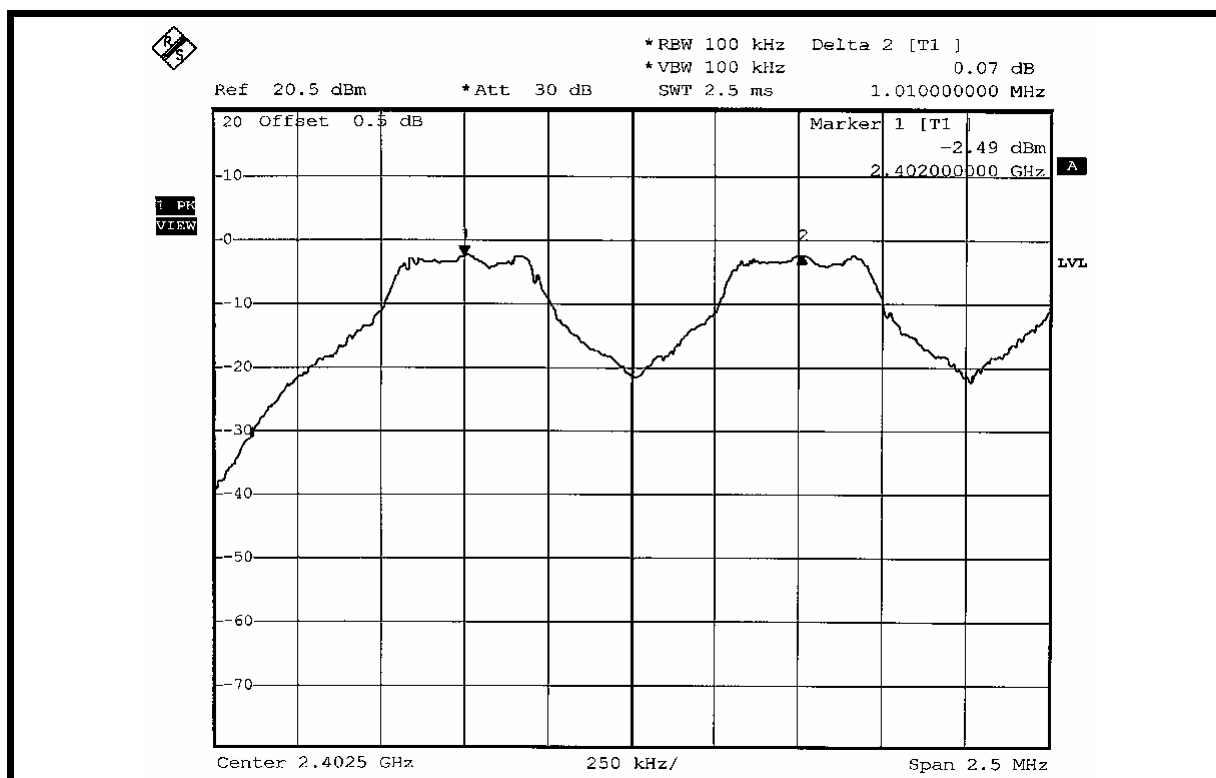

CH 39

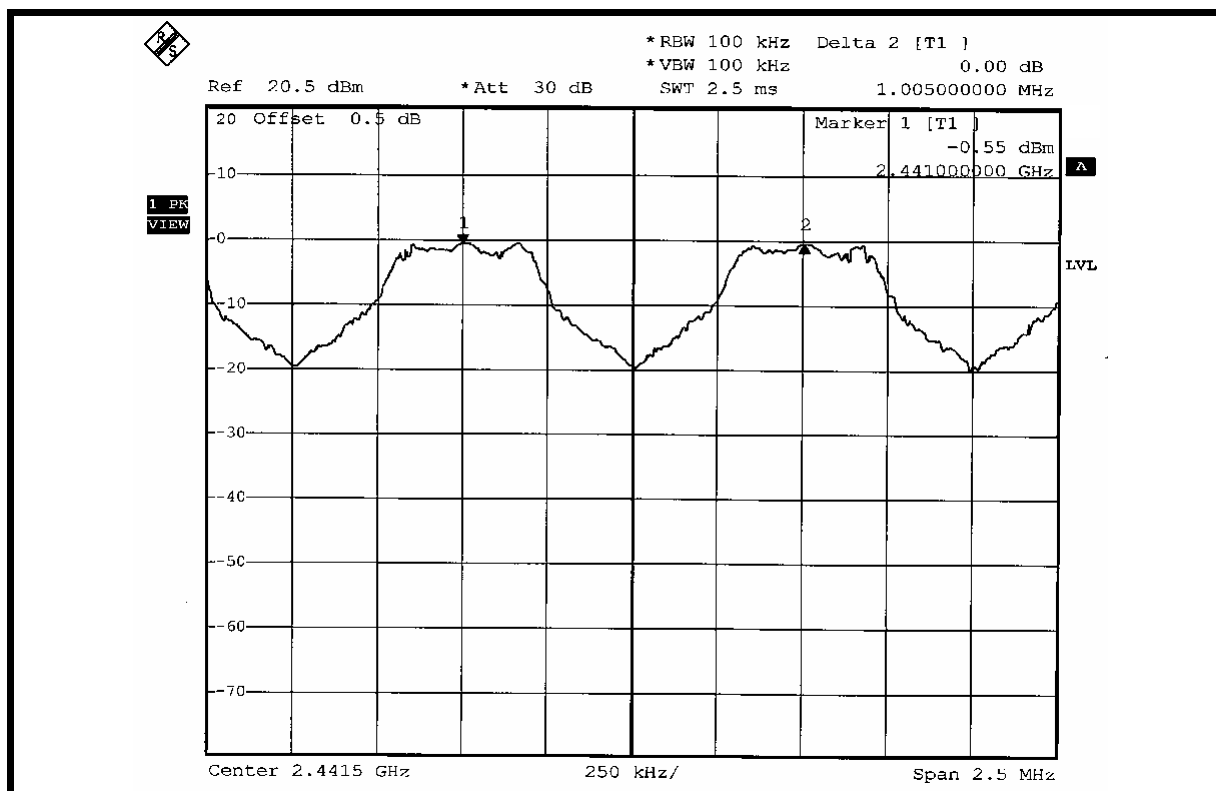

CH 78

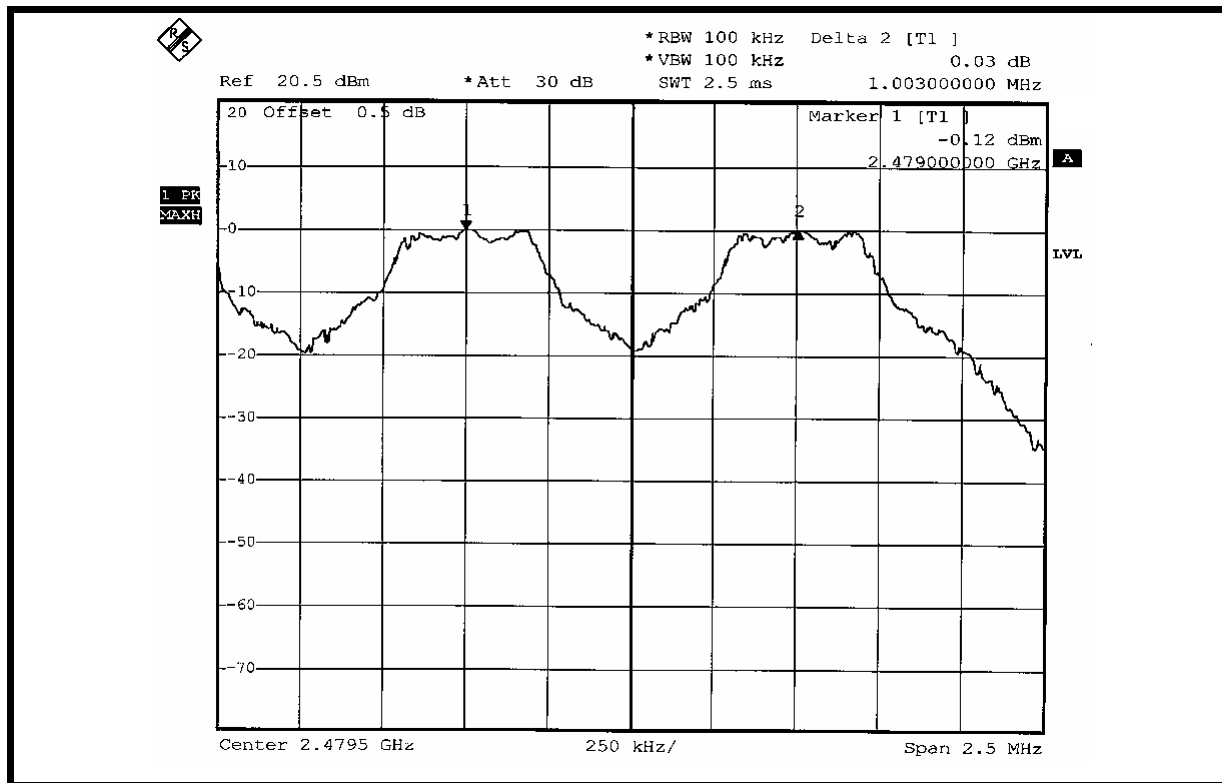



4.7 MAXIMUM PEAK OUTPUT POWER

4.7.1 LIMITS OF MAXIMUM PEAK OUTPUT POWER MEASUREMENT

The Maximum Peak Output Power Measurement is 30dBm.

4.7.2 TEST INSTRUMENTS

| DESCRIPTION & MANUFACTURER | MODEL NO. | SERIAL NO. | CALIBRATED UNTIL |
|----------------------------|-----------|------------|------------------|
| SPECTRUM ANALYZER | FSP40 | 100040 | Jun. 07, 2007 |

NOTE: The calibration interval of the above test instruments is 12 months and the calibrations are traceable to NML/ROC and NIST/USA.

4.7.3 TEST PROCEDURES

- a. Check the calibration of the measuring instrument using either an internal calibrator or a known signal from an external generator.
- b. Turn on the EUT and connect it to measurement instrument. Then set it to any one convenient frequency within its operating range. Set a reference level on the measuring instrument equal to the highest peak value.
- c. The center frequency of the spectrum analyzer is set to the fundamental frequency and using 1 MHz RBW and 3 MHz VBW.
- d. Measure the captured power within the band and recording the plot.
- e. Repeat above procedures until all frequencies required were complete.

4.7.4 DEVIATION FROM TEST STANDARD

No deviation

4.7.5 TEST SETUP

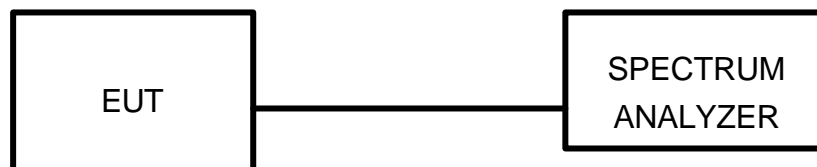

For the actual test configuration, please refer to the related Item – Photographs of the Test Configuration.

4.7.6 EUT OPERATING CONDITION

The software provided by client enabled the EUT to transmit and receive data at lowest, middle and highest channel frequencies individually.

4.7.7 TEST RESULTS

| | | | |
|-----------------------------|---------------|---------------------------------|-------------------------|
| MODULATION TYPE | GFSK | ENVIRONMENTAL CONDITIONS | 23deg. C, 68%RH, 991hPa |
| INPUT POWER (SYSTEM) | 120Vac, 60 Hz | TESTED BY | Long Chen |

| CHANNEL | CHANNEL FREQUENCY (MHz) | PEAK POWER OUTPUT (mW) | PEAK POWER OUTPUT (dBm) | PEAK POWER LIMIT (dBm) | PASS/FAIL |
|---------|-------------------------|------------------------|-------------------------|------------------------|-----------|
| 0 | 2402 | 0.628 | -2.02 | 30 | PASS |
| 39 | 2441 | 0.964 | -0.16 | 30 | PASS |
| 78 | 2480 | 1.064 | 0.27 | 30 | PASS |

CH 0

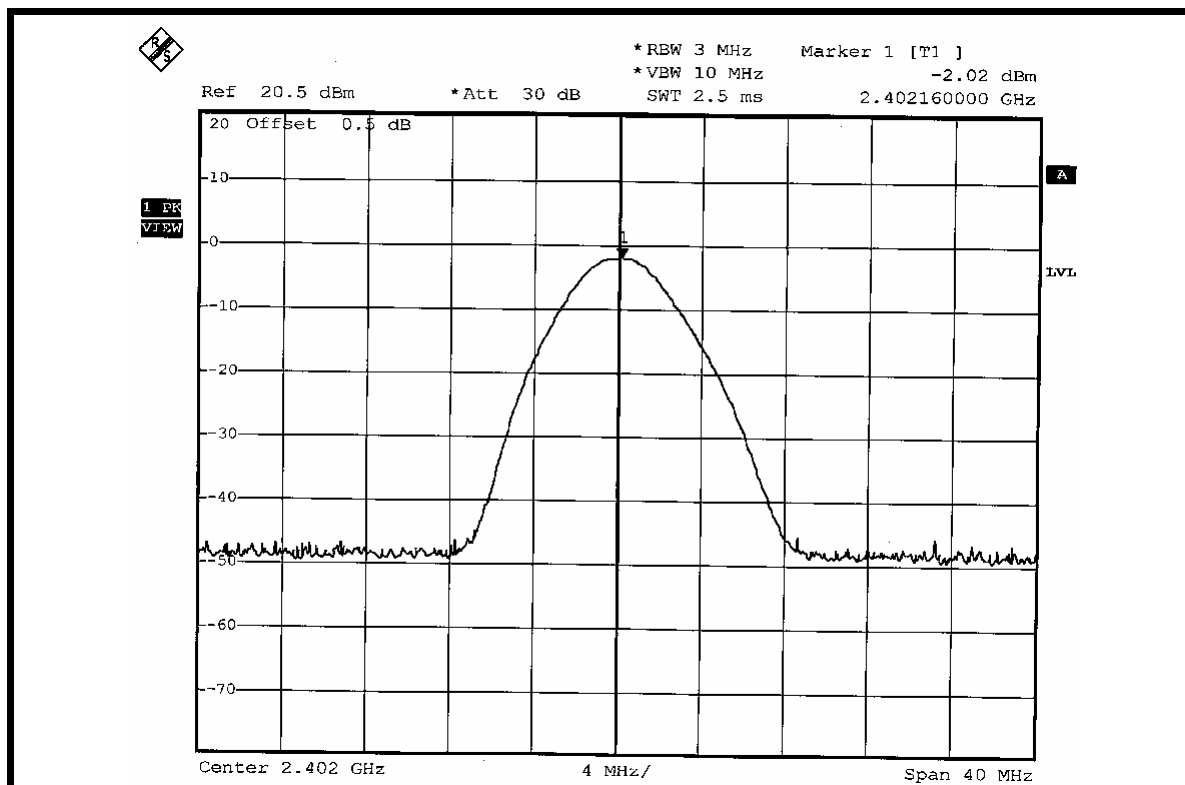

CH 39

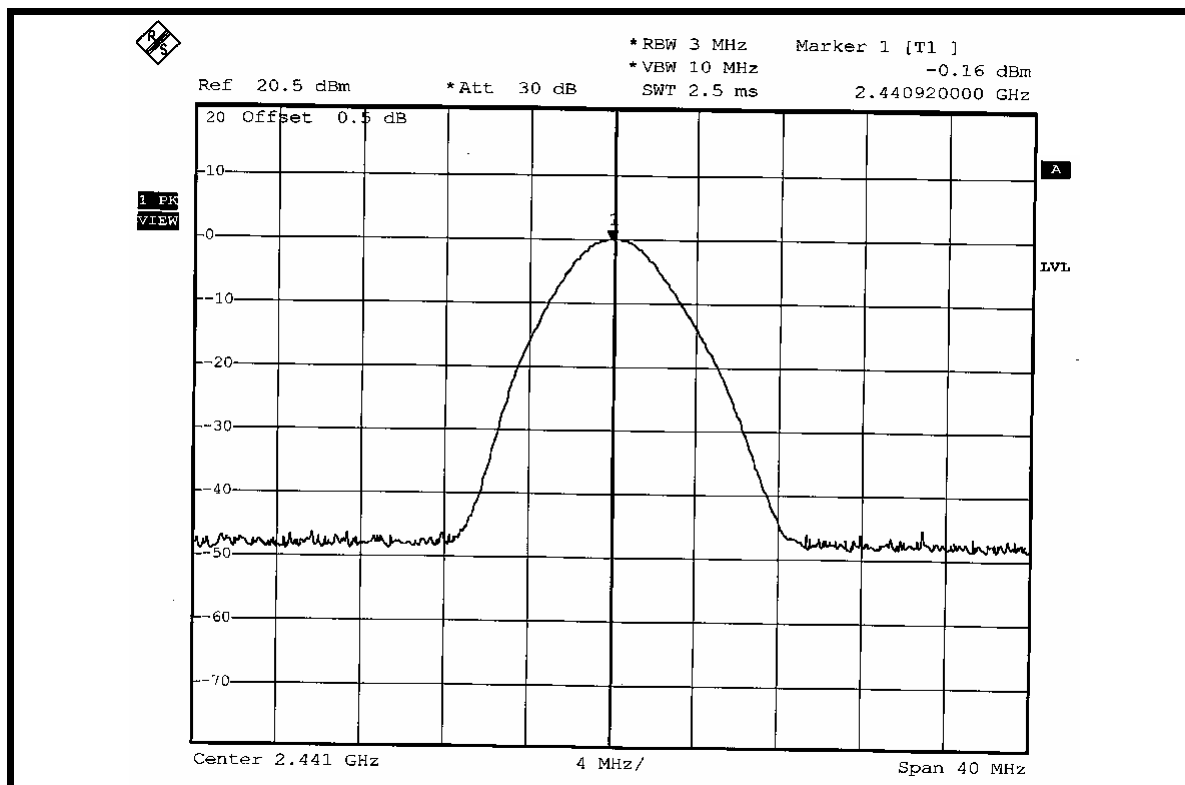

CH 78

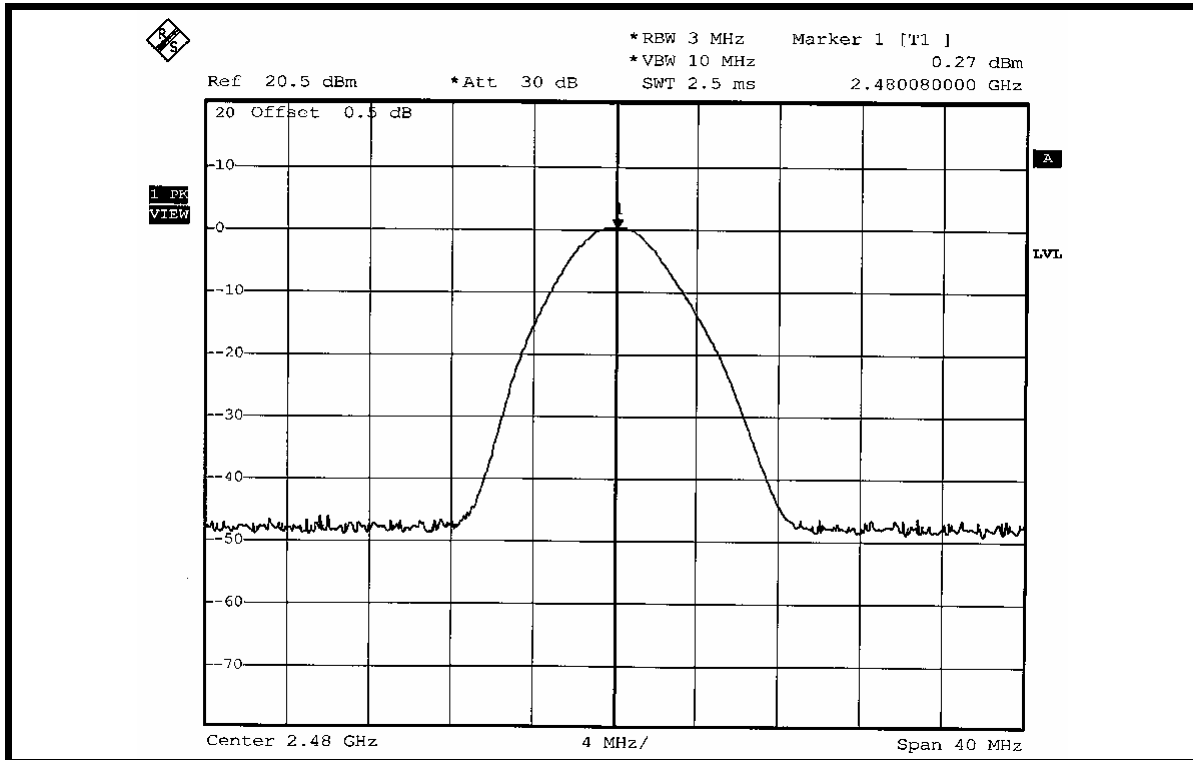



4.8 BAND EDGES MEASUREMENT

4.8.1 LIMITS OF BAND EDGES MEASUREMENT

Below -20dB of the highest emission level of operating band (in 100KHz RBW).

4.8.2 TEST INSTRUMENTS

| DESCRIPTION & MANUFACTURER | MODEL NO. | SERIAL NO. | CALIBRATED UNTIL |
|----------------------------|-----------|------------|------------------|
| SPECTRUM ANALYZER | FSP40 | 100040 | Jun. 07, 2007 |

NOTES: The calibration interval of the above test instruments is 12 months. And the calibrations are traceable to NML/ROC and NIST/USA.

4.8.3 TEST PROCEDURE

The transmitter output was connected to the spectrum analyzer via a low loss cable. Set both RBW and VBW of spectrum analyzer to 100 kHz with suitable frequency span including 100 MHz bandwidth from band edge. The band edges was measured and recorded.

4.8.4 DEVIATION FROM TEST STANDARD

No deviation.

4.8.5 EUT OPERATING CONDITION

The software provided by client enabled the EUT to transmit and receive data at lowest, middle and highest channel frequencies individually.



4.8.6 TEST RESULTS

The spectrum plots are attached on the following 4 images. D1 line indicates the highest level, D2 line indicates the 20dB offset below D1. It shows compliance with the requirement in part 15.247(d).

NOTE 1:

The band edge emission plot on the next page shows 45.86dBc between carrier maximum power and local maximum emission in restrict band (2.35508GHz). The emission of carrier strength list in the test result of channel 0 at the item 5.2.7 is 87.82dBuV/m (Peak), so the maximum field strength in restrict band is $87.82 - 45.86 = 41.96$ dBuV/m, which is under 74 dBuV/m limit.

Average value = $41.96 - 30.00 = 11.96$ dBuV/m, which is under 54dBuV/m limit.

*The DH5 packet was the worse case duty cycle for a transmit dwell time on a channel, based upon bluetooth theory the transmitter is on $0.625 * 5$ per 296.25 ms per channel. Therefore, the duty cycle be equal to: $20\log(3.125/100) = -30$ dB.

Average value = peak reading -30

NOTE 2:

The band edge emission plot on the next second page shows 48.95dBc between carrier maximum power and local maximum emission in restrict band (2.48482GHz). The emission of carrier strength list in the test result of channel 78 at the item 5.2.7 is 92.37dBuV/m (Peak), so the maximum field strength in restrict band is $92.37 - 48.95 = 43.42$ dBuV/m, which is under 74 dBuV/m limit.

Average value = $43.42 - 30.00 = 13.42$ dBuV/m, which is under 54dBuV/m limit.

*The DH5 packet was the worse case duty cycle for a transmit dwell time on a channel, based upon bluetooth theory the transmitter is on $0.625 * 5$ per 296.25 ms per channel. Therefore, the duty cycle be equal to: $20\log(3.125/100) = -30$ dB.

Average value = peak reading -30

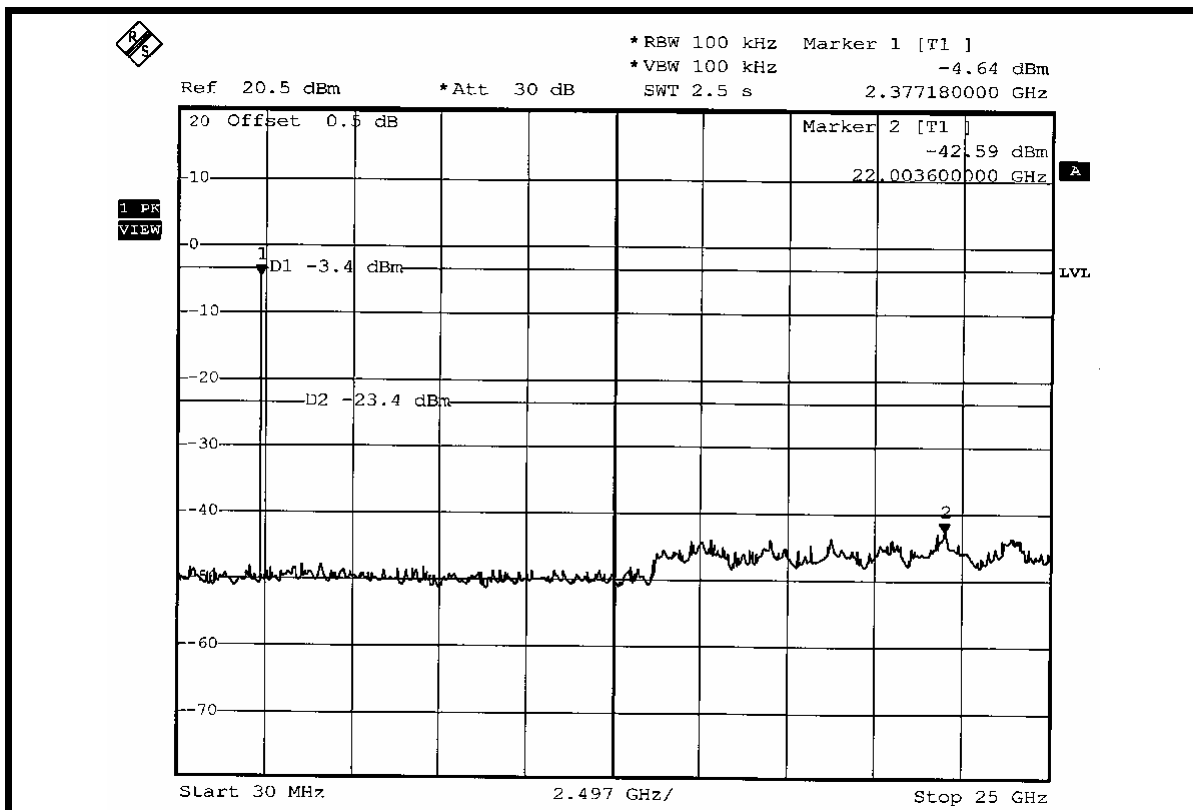
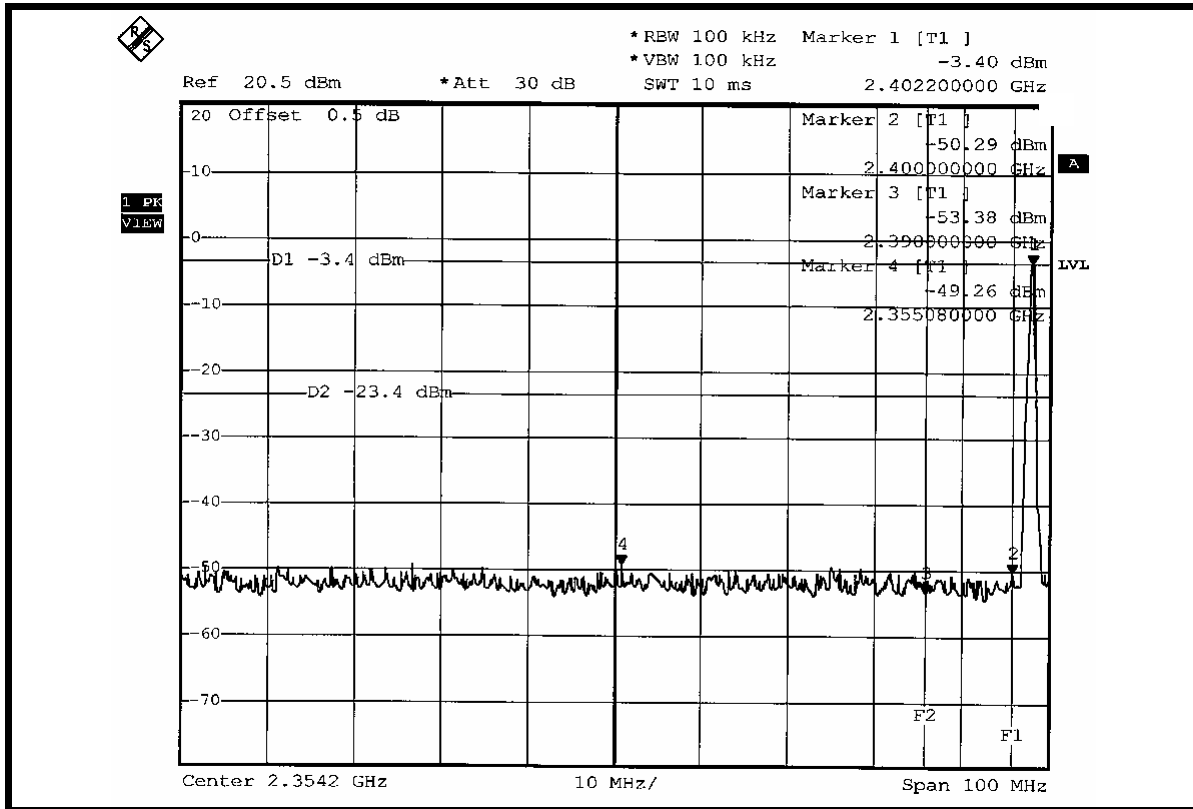



4.9 ANTENNA REQUIREMENT

4.9.1 STANDARD APPLICABLE

For intentional device, according to FCC 47 CFR Section 15.203, an intentional radiator shall be designed to ensure that no antenna other than that furnished by the responsible party shall be used with the device.

And according to FCC 47 CFR Section 15.247 (b), if transmitting antennas of directional gain greater than 6dBi are used, the power shall be reduced by the amount in dB that the directional gain of the antenna exceeds 6dBi.

4.9.2 ANTENNA CONNECTED CONSTRUCTION

The antenna used in this product is PIFA antenna without antenna connector. The maximum gain of this antenna is 0dBi.



5. INFORMATION ON THE TESTING LABORATORIES

We, ADT Corp., were founded in 1988 to provide our best service in EMC, Radio, Telecom and Safety consultation. Our laboratories are accredited and approved by the following approval agencies according to ISO/IEC 17025.

| | |
|--------------------|-----------------------|
| USA | FCC, UL, A2LA |
| GERMANY | TUV Rheinland |
| JAPAN | VCCI |
| NORWAY | NEMKO |
| CANADA | INDUSTRY CANADA , CSA |
| R.O.C. | CNLA, BSMI, NCC |
| NETHERLANDS | Telefication |
| SINGAPORE | PSB , GOST-ASIA (MOU) |
| RUSSIA | CERTIS (MOU) |

Copies of accreditation certificates of our laboratories obtained from approval agencies can be downloaded from our web site:

www.adt.com.tw/index.5/phtml. If you have any comments, please feel free to contact us at the following:

Linko EMC/RF Lab:

Tel: 886-2-26052180
Fax: 886-2-26052943

Hsin Chu EMC/RF Lab:

Tel: 886-3-5935343
Fax: 886-3-5935342

Hwa Ya EMC/RF/Safety Telecom Lab:

Tel: 886-3-3183232
Fax: 886-3-3185050

Web Site: www.adt.com.tw

The address and road map of all our labs can be found in our web site also.



APPENDIX-A

MODIFICATIONS RECORDERS FOR ENGINEERING CHANGES TO THE EUT BY THE LAB

No any modifications are made to the EUT by the lab during the test